

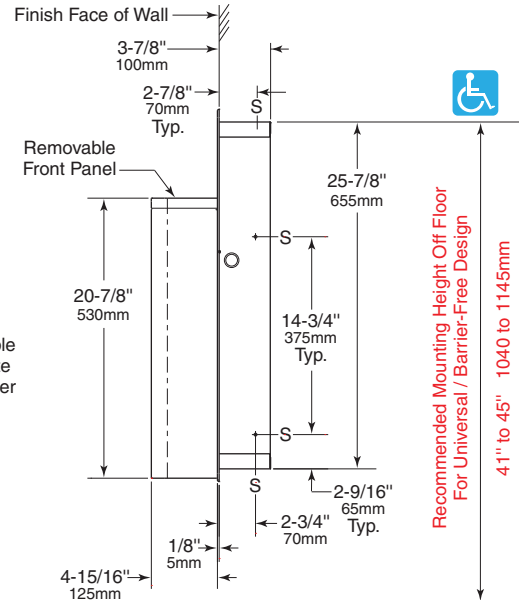

Technical Data

ConturaSeries® RECESSED WASTE RECEPTACLE

B-43644

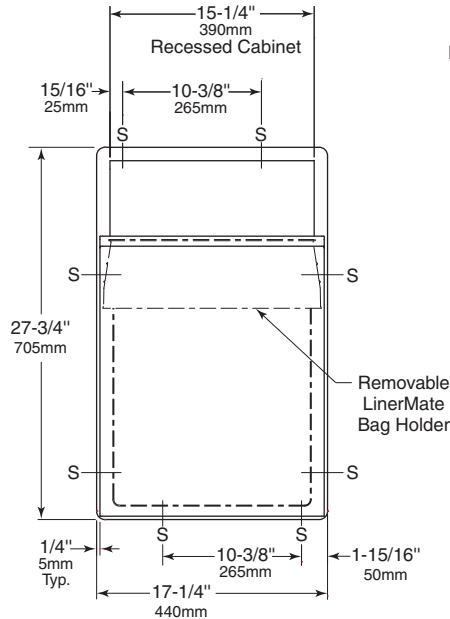

Rough Wall Opening
 15-7/8" (405mm) wide
 26-1/4" (665mm) high
 4" (100mm) minimum recessed depth

MATERIALS:

Cabinet — 18-8 S, type-304, 22-gauge (0.8mm) stainless steel. All-welded construction. Exposed surfaces have satin-finish.

Flange — 18-8 S, type-304, 22-gauge (0.8mm) stainless steel with satin-finish. Drawn, one-piece, seamless construction. Radius on corners and return edges complement side edges of waste receptacle.

Waste Receptacle — 18-8 S, type-304, 22-gauge (0.8mm) stainless steel with satin-finish. Formed, one-piece, seamless construction. Removable front panel has same degree of arc as other Bobrick ConturaSeries washroom accessories. Top edge hemmed for safe handling. Radius on side edges of waste receptacle complement other ConturaSeries accessories. Secured to cabinet with two keyholes over studs on bottom and two tamper-resistant setscrews on top. Capacity: 12.8-gal. (48.3-L).

LinerMate® Trash Liner Holder — Unit equipped with LinerMate to facilitate installation and removal of disposable trash liners and retains liner inside waste receptacle. LinerMate trash liner holder is fabricated with a molded plastic bag holder sleeve and a 20-gauge (0.91mm) stainless steel, U-shaped support strap; riveted construction. Bag holder shall have an arc at front and same shape as inside of waste receptacle area.

OPERATION:

To insert disposable plastic trash bag, lift LinerMate bag holder up and forward and rest over edge of waste receptacle front panel with the bottom notches of LinerMate engaged on top front edge of receptacle. Place plastic trash bag inside LinerMate and fold plastic bag over LinerMate sleeve. Tie a knot in the corner of the bag, then place LinerMate with plastic trash bag back into receptacle. To empty, gather disposable plastic trash bag from LinerMate bag holder sleeve and lift bag up. Front of waste receptacle panel is removable for cleaning cabinet interior.

continued . . .

INSTALLATION:

Provide framed rough wall opening 15-7/8" wide x 26-1/4" high (405 x 665mm). Minimum recessed depth required to finish face of wall is 4" (100mm). Allow clearance for construction features that may protrude into rough wall opening from opposite wall. Coordinate with mechanical engineer to avoid pipes, vents, and conduits. If unit projects above top of wainscot, provide aluminum channel or other filler to eliminate gap between flange and finish face of wall. Mount unit in wall opening with shims between framing and cabinet at all points indicated by an S, then secure unit with #8 x 1-1/4" (4.2 x 32mm) screws (not furnished).

SPECIFICATION:

Recessed waste receptacle shall be type-304 stainless steel with all-welded construction; exposed surfaces shall have satin finish. Front of waste receptacle shall have same degree of arc and match other Bobrick ConturaSeries accessories in the washroom. Radius on corners and edges of flange and waste receptacle shall complement other Bobrick ConturaSeries washroom accessories. Flange shall be drawn, one-piece, seamless construction. Waste receptacle shall have a formed, one-piece, seamless, removable front panel with top edge hemmed. Waste receptacle shall be equipped with LinerMate to facilitate installation and removal of disposable trash liners and retains liner inside waste receptacle. LinerMate trash liner holder is fabricated with a molded plastic bag holder sleeve and a 20-gauge (0.91mm) stainless steel, U-shaped support strap; riveted construction. Bag holder shall have an arc at front and same shape as inside of waste receptacle area. Capacity of waste receptacle shall be 12.8-gal. (48.3-L).

Recessed Waste Receptacle shall be Model B-43644 of Bobrick Washroom Equipment, Inc., Clifton Park, New York; Jackson, Tennessee; Los Angeles, California; Bobrick Washroom Equipment Company, Scarborough, Ontario; Bobrick Washroom Equipment Pty. Ltd., Australia; and Bobrick Washroom Equipment Limited, United Kingdom.