

Est. 1957

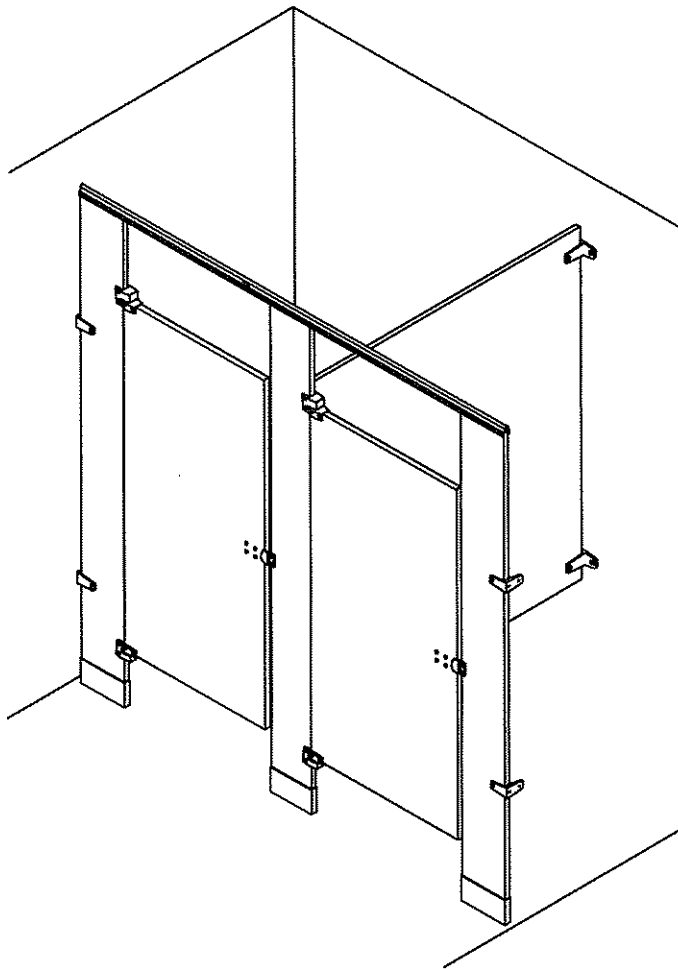

MANNINGMATERIALSINC

INSTALLATION INSTRUCTIONS FOR
PLASTIC LAMINATE PARTITIONS



509 LIGON DRIVE NASHVILLE, TN 37204 PH: 615-248-1001 FAX: 615-254-7835
INFO@MANNINGMATERIALSINC.COM | WWW.MANNINGMATERIALSINC.COM

Table Of Contents

<u>Floor Anchored/Overhead Braced</u>	<u>Page</u>
Step 1,2,3.....	1
Step 4,5,6.....	2
Panel To Pilaster/Wall Two Ear Assembly.....	3
Panel To Pilaster/Wall One Ear Assembly.....	4
Pilaster/Wall One Ear Assembly.....	5
Pilaster/Panel Alcove Assembly.....	6
Pilaster/Panel Inline Assembly.....	7
Door Hardware Assembly.....	8 & 8A
Headrail Assembly.....	9
Urinal Screen Assembly.....	10

<u>Floor Anchored</u>	<u>Page</u>
Step 1,2,3.....	11
Step 4,5,6.....	12
Panel To Pilaster/Wall Two Ear Assembly.....	13
Panel To Pilaster/Wall One Ear Assembly.....	14
Pilaster/Wall One Ear Assembly.....	15
Pilaster/Panel Alcove Assembly.....	16

<u>Ceiling Anchored</u>	<u>Page</u>
Step 1,2,3.....	17
Step 4,5,6.....	18
Panel To Pilaster/Wall Two Ear Assembly.....	19
Panel To Pilaster/Wall One Ear Assembly.....	20
Pilaster/Wall One Ear Assembly.....	21
Pilaster/Panel Alcove Assembly.....	22

Table Of Contents

<u>Floor Anchored And Ceiling Anchored</u>	<u>Page</u>
Step 1,2,3.....	23
Step 4,5,6.....	24
Panel To Pilaster/Wall Two Ear Assembly.....	25
Panel To Pilaster/Wall One Ear Assembly.....	26
Pilaster/Wall One Ear Assembly.....	27
Pilaster/Panel Alcove Assembly.....	28
Pilaster/Panel Inline Assembly.....	29
<u>Full Height Aluminum Kits</u>	<u>Page</u>
Panel To Pilaster/Wall Two Ear Assembly.....	30
Panel To Pilaster/Wall One Ear Assembly.....	31
Pilaster/Wall One Ear Assembly.....	32
Urinal Screen Assembly.....	33
<u>Product Information</u>	<u>Page</u>
Care And Maintenance Of Toilet Partitions.....	34

The Components for this project have been custom fabricated. They are guaranteed with respect to manufacture and workmanship and were inspected at the factory.

Before beginning work, the units should be inspected. If damage occurred in transit, report immediately to the freight company or other agencies that may have caused the damage.

STEP 1 FLOOR ANCHORED/OVERHEAD BRACED

FIGURE 1

NOTE: FLOOR MUST BE CONCRETE

- Review the layout drawings and package lists that have accompanied this job.
- Establish and mark pilaster center line from back wall.
- Establish and mark panel center lines for wall brackets.
- Establish pilaster floor fastener locations from side wall according to shop drawings. (Note: Floor fasteners are located 1" from edge of pilaster).
- Mark wall bracket holes using brackets as templates.

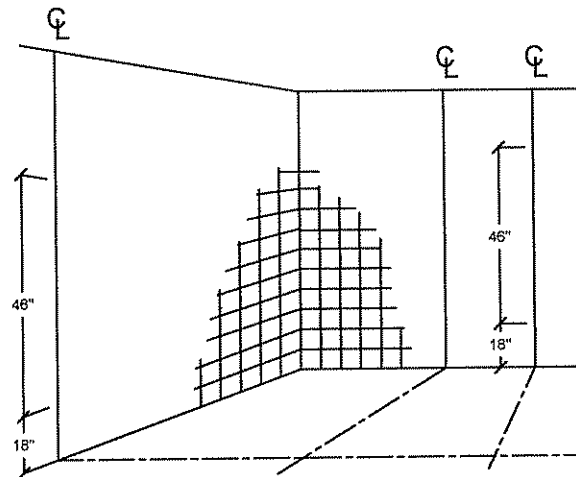

STEP 2 WALL BRACKETS AND FLOOR BRACKETS

FIGURE 2

- Drill holes for wall brackets and floor fastenings of appropriate size for particular fastening devices supplied.
- Before proceeding, confirm that backing of walls and floor is adequate to support secure mounting of the toilet compartment units.
- Insert anchoring devices in walls and secure wall brackets.
- Install wedge anchor, shoe clip, washer and nut into concrete floor and tighten.

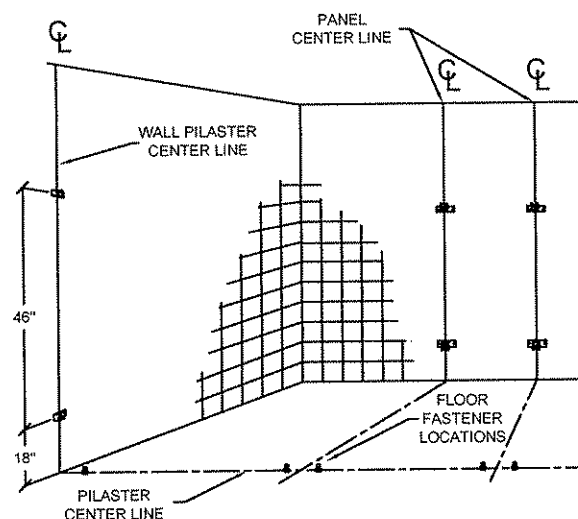

STEP 3 POSITION PANEL

FIGURE 3

- Place panel on a support, 12" above the floor.
- Set it into wall brackets, but do not fasten panel at this time.

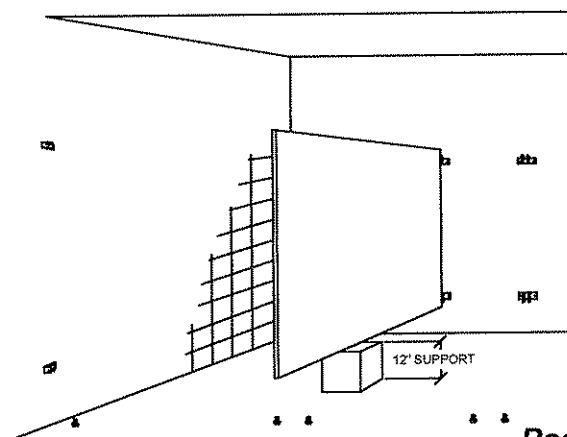

STEP 4

PILASTER PREPARATION

- Align U-brackets in position on rear of pilasters. Refer to layout drawings and make sure brackets are in alignment with wall brackets.
- Fasten U-brackets to pilaster with sheet metal screws.
- Pilasters at wall do not require U-brackets, but should be prepared for wall and floor fastening as required by compartment layout.

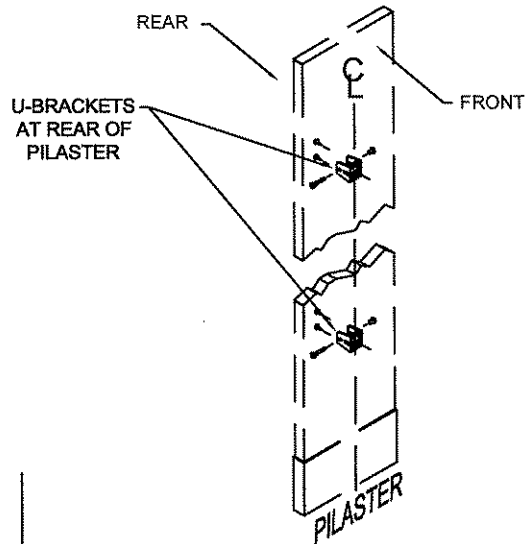
FIGURE 4

STEP 5

INSTALL PILASTERS

- Slide stainless steel shoe carefully over mounting end of pilaster and leave approximately 5" above end.
- Thread support nuts and mounting washers over wedge anchor to support pilaster mounting bar.
- Position pilaster and mounting bar on threaded anchor and attach lightly with square flat washer, lockwasher and locking nut.

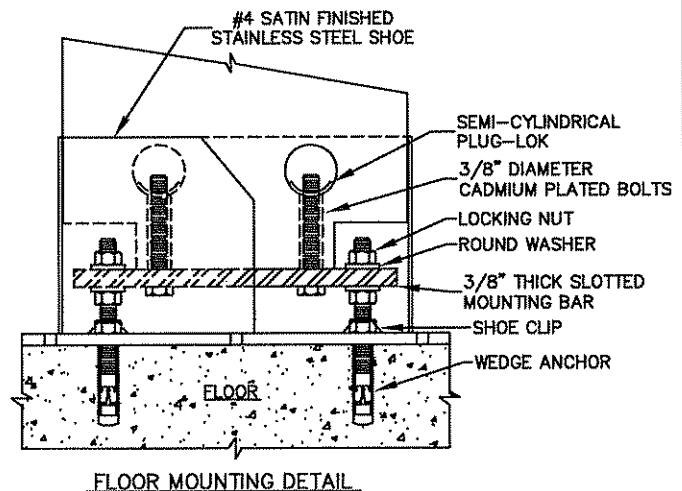
FIGURE 5

STEP 6

SECURING PILASTERS/PANELS

- Level each pilaster by adjusting both support nuts to desired position.
- Plumb each pilaster and fasten the pilaster to panel using through bolts or sheet metal screws.
- Establish door openings by setting pilaster mounting bar to desired position on anchor.
- Tighten locking nuts on top of pilaster mounting bar.
- Slide stainless steel shoe down to floor, firmly engaging shoe clips.
- Fasten panel to wall brackets using through bolts.
- Remove panel support device.

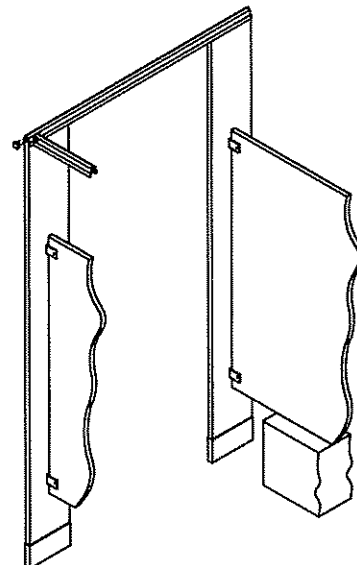
FIGURE 6







**FLOOR ANCHORED/OVERHEAD BRACED
PANEL TO PILASTER/WALL
TWO EAR ASSEMBLY
PLASTIC LAMINATE**

Pilasters must be both plumb and level. To assist in leveling, headrail may be lightly positioned across adjacent pilasters (do not fasten at this time). Refer to steps 4 & 6.

A. Fasten panel to 2-Ear bracket at wall with through bolts.

B. Plumb pilaster and fasten pilaster to panel using through bolts or sheet metal screws to "U" brackets.

Panel Hardware Kit (P/N 8515020) Includes:
CHROME PLATED ZAMAC

PART ID.	DESCRIPTION	QTY
1	 2511750 Two Ear Bracket	(2)
2	 2511910 "U" Bracket	(2)
3	 3910600 Theft Resistant C/P Step Bolts 1" Long	(4)
4	 3910690 Theft Resistant C/P Barrel Nut	(4)
5	 3910450 Theft Resistant C/P #14 x 2 1/2" S.M.S	(4)
6	 3080000 Plastic Shields	(4)
7	 3914120 Theft Resistant C/P #14 x 5/8" S.M.S	(12)

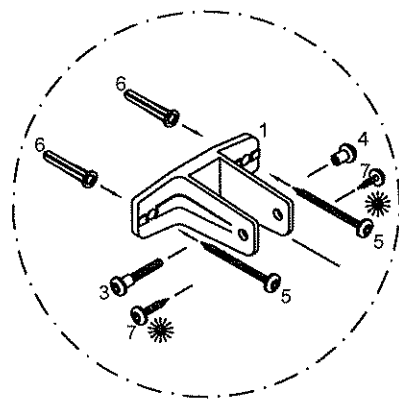
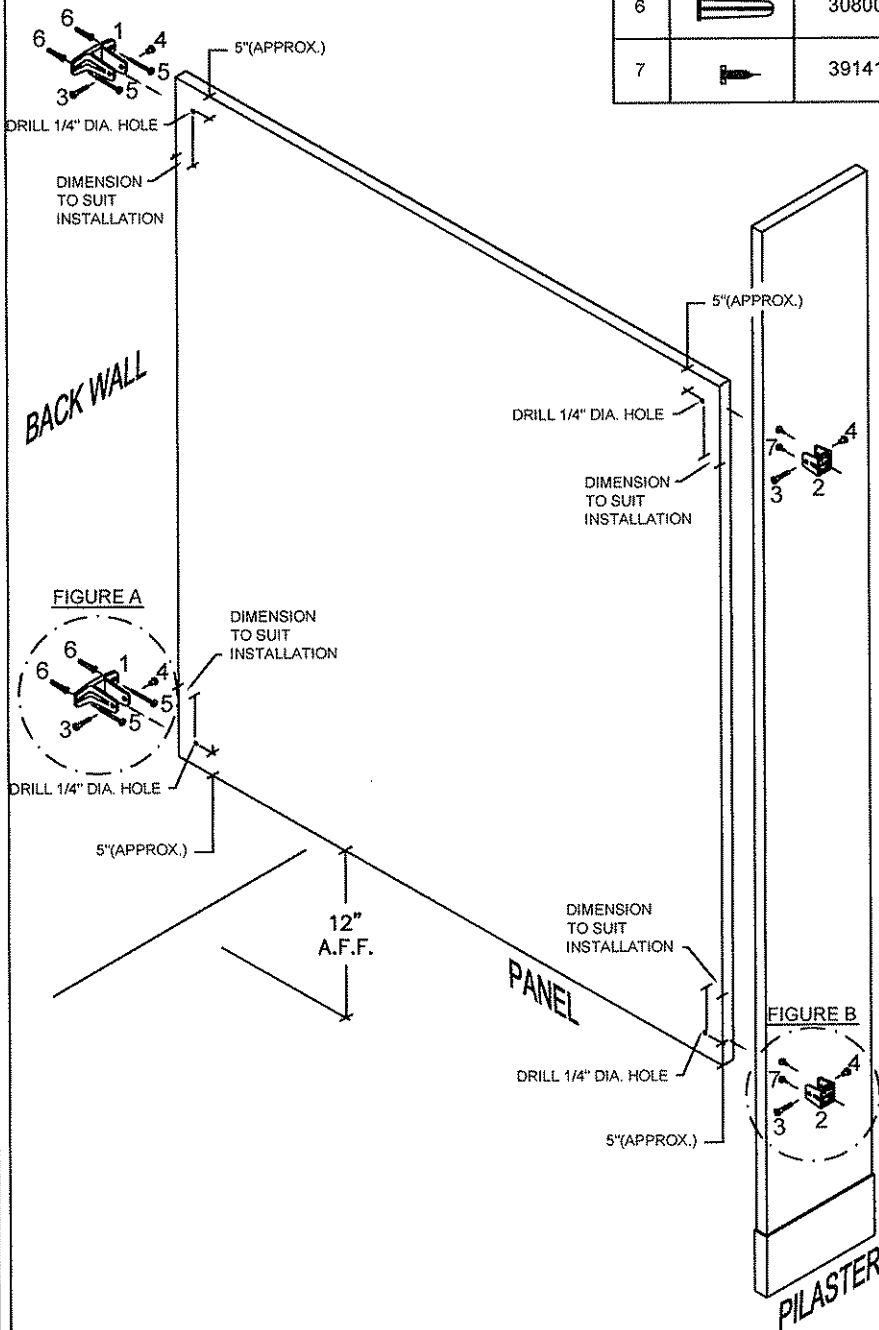

FIGURE A

☼ **OPTIONAL**
Two #3914120 Theft resistant C/P #14 X 5/8"
May be Used (But Not Recommended)
To Fasten brackets To Panel.

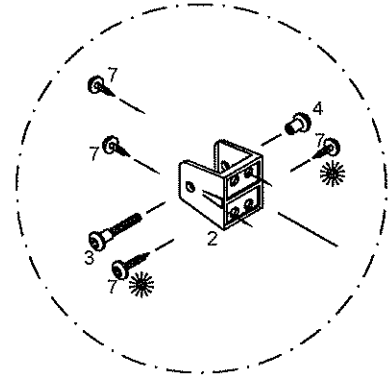









FIGURE B

NOTE:
Use Only Two #3914120 Theft resistant C/P #14 X 5/8"
To Diagonally Fasten U-bracket To Pilaster.

**FLOOR ANCHORED/OVERHEAD BRACED
 PANEL TO PILASTER/WALL
 ONE EAR ASSEMBLY
 PLASTIC LAMINATE**

Pilasters must be both plumb and level. To assist in leveling, headrail may be lightly positioned across adjacent pilasters (do not fasten at this time). Refer to steps 4 & 6.

- A. Fasten panel to 1-Ear bracket at wall with through bolts.
- B. Plumb pilaster and fasten pilaster to panel using through bolts or sheet metal screws to "U" brackets.

Panel Hardware Kit (P/N 8515010) Includes: CHROME PLATED ZAMAC			
PART ID.		DESCRIPTION	QTY
1		2511760 One Ear Bracket	(2)
2		2511910 "U" Bracket	(2)
3		3910600 Theft Resistant C/P Step Bolts 1" Long	(4)
4		3910690 Theft Resistant C/P Barrel Nut	(4)
5		3910450 Theft Resistant C/P #14 x 2 1/2" S.M.S	(4)
6		3080000 Plastic Shields	(4)
7		3914120 Theft Resistant C/P #14 x 5/8" S.M.S	(12)

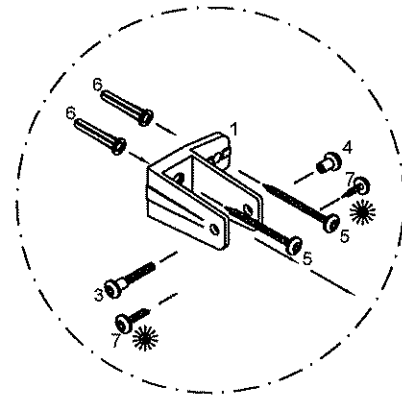
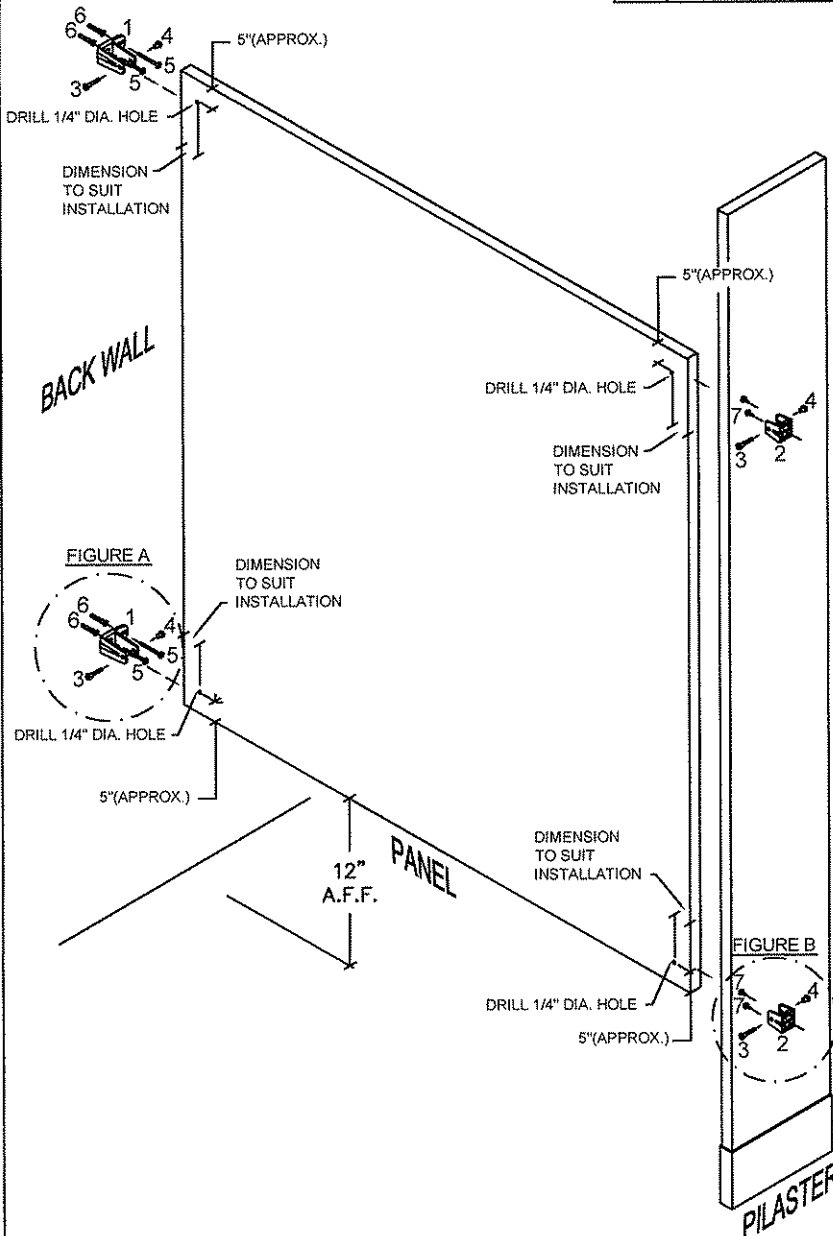

FIGURE A

OPTIONAL
 Two #3914120 Theft resistant C/P #14 X 5/8"
 May be Used (But Not Recommended)
 To Fasten brackets To Panel.

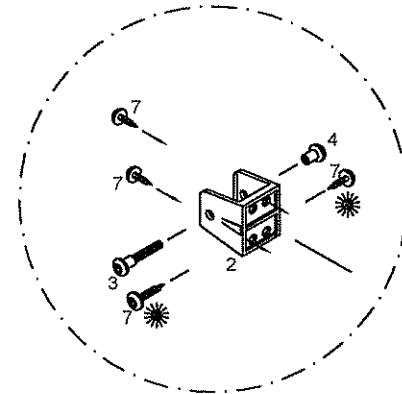



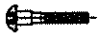



FIGURE B

NOTE:
 Use Only Two #3914120 Theft resistant C/P #14 X 5/8"
 To Diagonally Fasten U-bracket To Pilaster.

**FLOOR ANCHORED/OVERHEAD BRACED
PILASTER/WALL
ASSEMBLY
PLASTIC LAMINATE**

Pilasters must be both plumb and level. To assist in leveling, headrail may be lightly positioned across adjacent pilasters (do not fasten at this time).

- A. Fasten pilaster to wall bracket using through bolts or sheet metal screws.
- B. Establish door openings by adjusting pilaster mounting bar to desired position and tighten nuts. Refer to step 6.

Pilaster/Wall Hardware Kit (P/N 8515210) Includes: CHROME PLATED ZAMAC			
PART ID.		DESCRIPTION	QTY
1		2511840 One Ear Wall Bracket	(2)
2		3910700 Theft Resistant C/P Step Bolts 1 1/4" Long	(2)
3		3910690 Theft Resistant C/P Barrel Nut	(2)
4		3910450 Theft Resistant C/P #14 x 2 1/2" S.M.S	(4)
5		3080000 Plastic Shields	(4)
6		3914120 Theft Resistant C/P #14 x 5/8" S.M.S	(8)

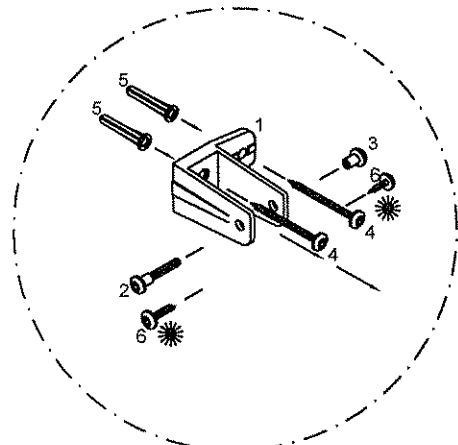
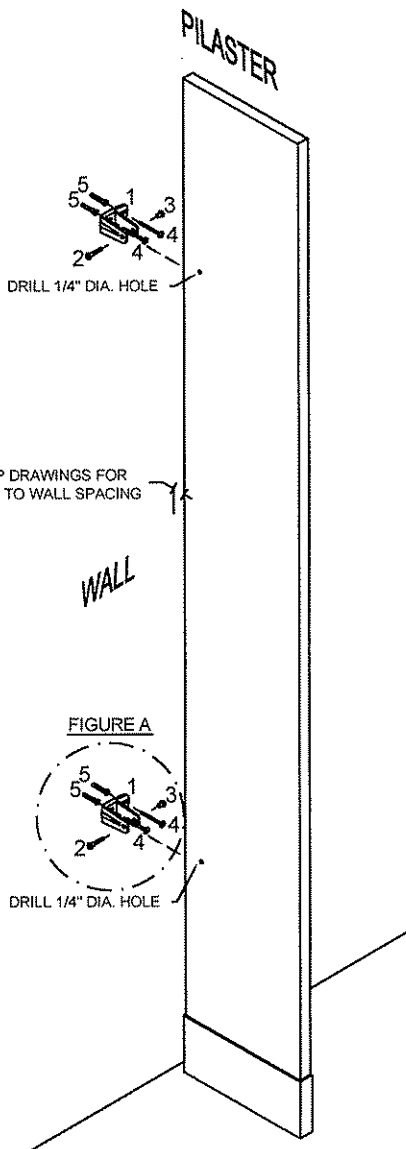
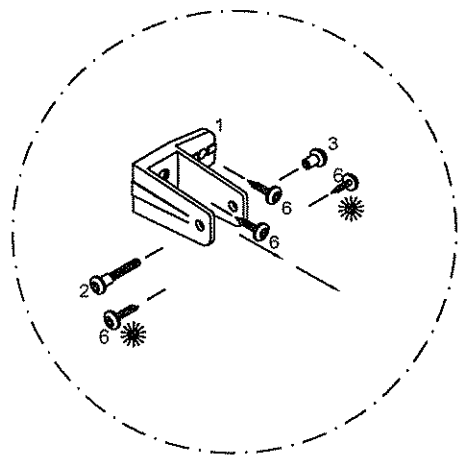

FIGURE A

☼ **OPTIONAL**
 Two #3914120 Theft resistant C/P #14 X 5/8"
 May be Used (But Not Recommended)
 To Fasten brackets To Panel.













NOTE:
 Replace #3910450 Theft Resistant C/P #14 x 2 1/2"
 With #3914120 Tamper resistant C/P #14 X 5/8"
 To Fasten Pilaster To Panel.

FIGURE B



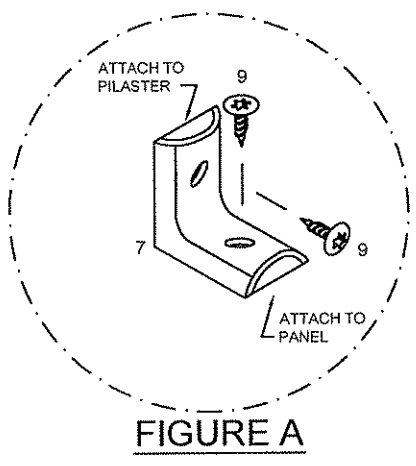
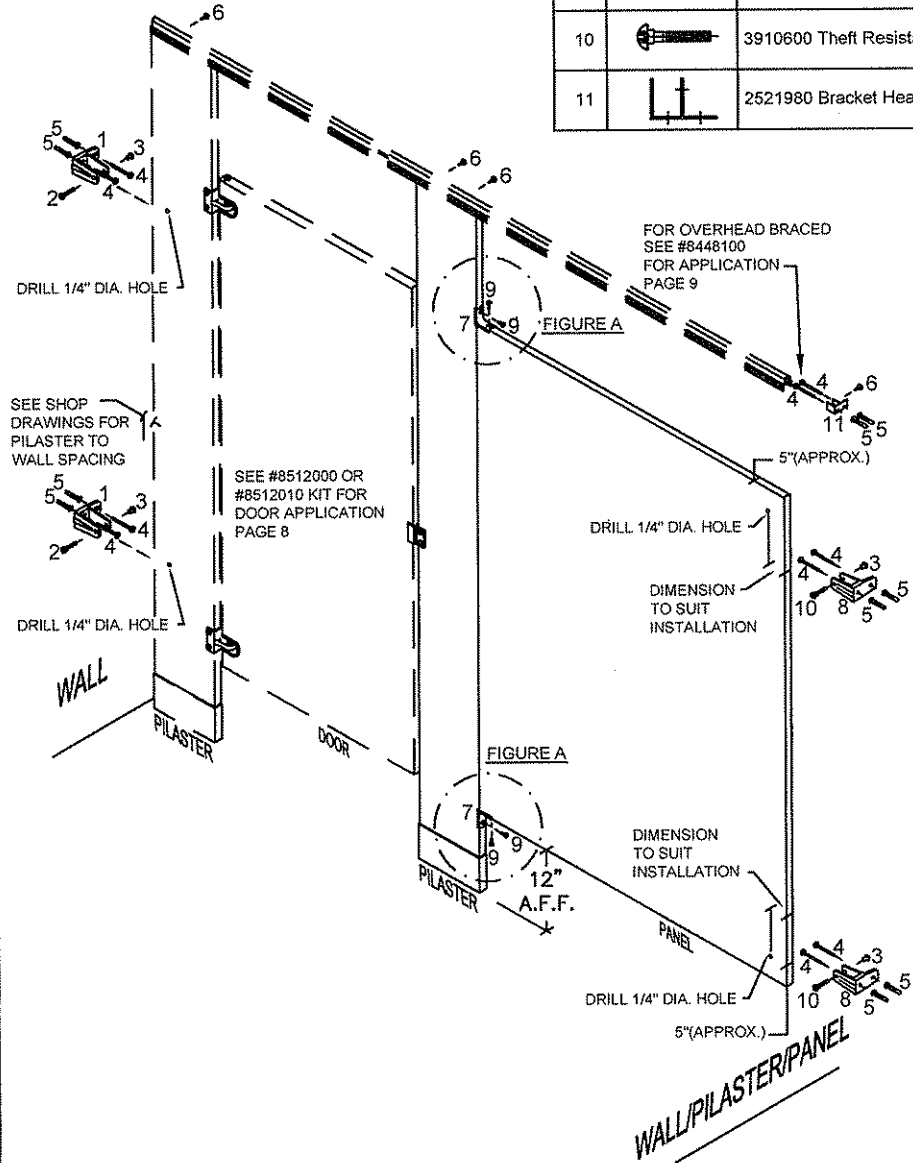

**FLOOR ANCHORED/
 OVERHEAD BRACED
 PILASTER/PANEL ALCOVE
 ASSEMBLY ONE EAR
 PLASTIC LAMINATE**

Replace #8517310 with #8517320 for two ear bracket kit.

Alcove Hardware Kit (P/N 8517310) Includes: CHROME PLATED ZAMAC		
PART ID.	DESCRIPTION	QTY
1	 2511840 1 1/4" One Ear Wall Bracket	(2)
2	 3910700 Theft Resistant C/P Step Bolts #10 -24 x 1 1/4" Long	(2)
3	 3910690 Theft Resistant C/P Barrel Nut	(4)
4	 3910450 Theft Resistant C/P #14 x 2 1/2" S.M.S	(10)
5	 3080000 Plastic Shields	(10)
6	 3914120 Theft Resistant C/P #14 x 5/8" S.M.S (Balance For Fastening Pilaster /Panel)	(14)
7	 2511950 Alcove Clip	(2)
8	 2511760 1" One Ear Wall Bracket	(2)
9	 3910110 Theft Resistant C/P #10 x 1" S.M.S	(4)
10	 3910600 Theft Resistant C/P Step Bolts #10-24 x 1" Long	(2)
11	 2521980 Bracket Headrail Satin "F" Zamac	(1)



**FLOOR ANCHORED/
OVERHEAD BRACED
PILASTER/PANEL/PILASTER INLINE
ASSEMBLY
PLASTIC LAMINATE**

Alternate Alcove Hardware Kit (P/N 8517030) Includes: CHROME PLATED ZAMAC		
PART ID.	DESCRIPTION	QTY
1	 2518340 Alcove Clips	(12)
2	 3910600 Theft Resistant C/P Step Bolts #10-24 x 1" Long	(12)
3	 3910690 Theft Resistant C/P Barrel Nut	(12)
4	 3914120 Theft Resistant C/P #14 x 5/8" S.M.S	(24)

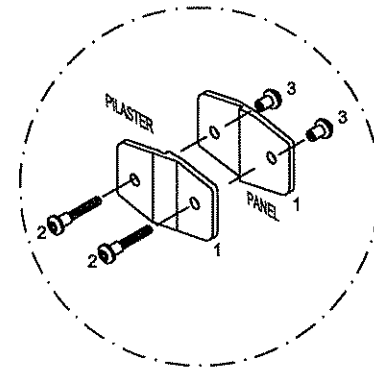
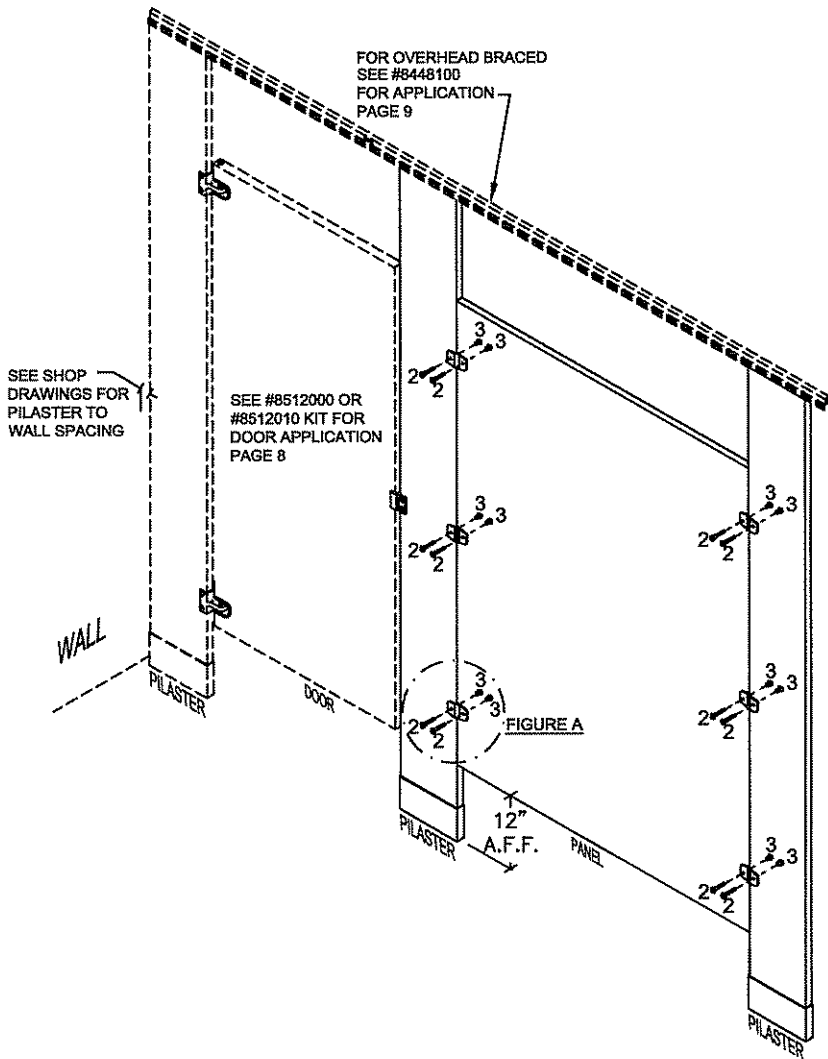

**FIGURE A
RECOMMENDED**

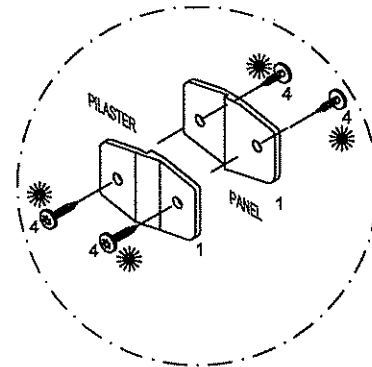

OPTIONAL

* Two #3914120 Theft resistant C/P #14 X 5/8" May be Used (But Not Recommended) To Fasten brackets To Panel. Offset brackets for screw clearance.

**DOOR HARDWARE
ASSEMBLY
PLASTIC LAMINATE**

- A. Insert a top nylon cam into the upper and lower door hinge insert closure bracket, as illustrated so that cam base is flush with inner bracket surface. See figure A
- B. Insert each door hinge insert (with top cam in place) into the upper and lower openings in the door, anchoring with #10 x 1" screw. See figure A
- C. Insert bottom nylon cam into the pilaster portion of the hinge bracket assembly. See figure B. The cam should be set to same desired position on upper and lower hinge assemblies. See figure C.
- D. Connect top and bottom hinge pilaster bracket to door & hinge. Insert with hinge pin through the top and bottom of the door until the pin is flush with the door edge.
- E. With hinges in place, position door so that the upper portion of hinge bracket is on pilaster at desired height.
- F. Secure top & bottom hinge pilaster bracket to pilaster with two through bolts.
- G. Install balance of hardware per this diagram.

Outswing Door Hardware Kit (P/N 8512004) Includes:
CHROME PLATED ZAMAC

PART ID.	DESCRIPTION	QTY
1	2512800 Hinge Pilaster Bracket	(2)
2	2512810 Door hinge insert	(2)
3	6082410 Hinge Pintle Nylon	(2)
4	6082400 Hinge Cam Nylon	(2)
5	2511710 Bumper	(1)
6	2511702 Pull Handle	(1)
7	2512710 Outswing Latch Slide Keeper	(1)
8	3912420 Hinge Pin	(2)
9	2511600 Bumper And Coathook	(1)
10	3910110 Theft Resistant C/P SM #10 x 1" Flat Head	(2)
11	3910700 Theft Resistant C/P Step Bolts 1 1/4" long	(5)
12	3910690 Theft Resistant C/P 5/8" Barrel Nut	(7)
13	3912130 Theft Resistant C/P S.M.S. #10 x 5/8"	(4)
14	2513900 Slide Latch Brushed Chrome	(1)
15	3910800 Theft Resistant C/P Step Bolts 1 1/2" long	(2)

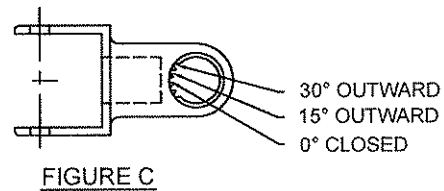
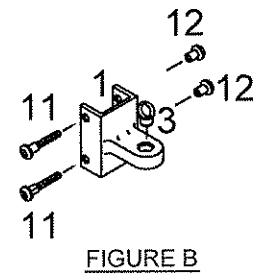
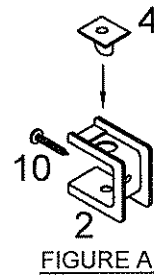
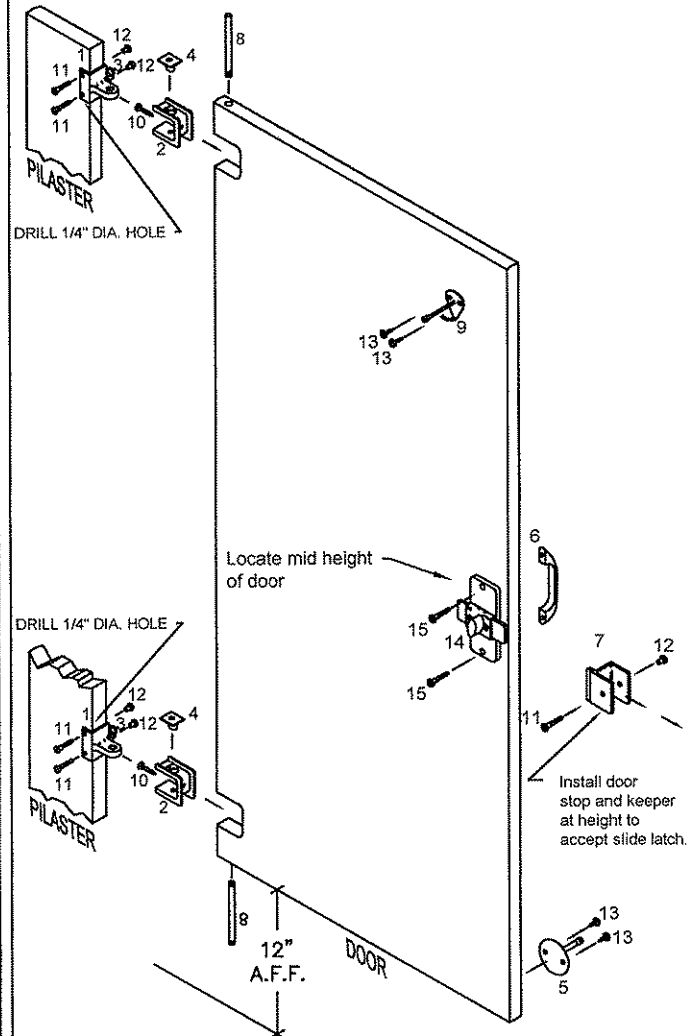

DOOR HARDWARE ASSEMBLY PLASTIC LAMINATE

- A. Insert a top nylon cam into the upper and lower door hinge insert closure bracket, as illustrated so that cam base is flush with inner bracket surface. See figure A
- B. Insert each door hinge insert (with top cam in place) into the upper and lower openings in the door, anchoring with #10 x 1" screw. See figure A
- C. Insert bottom nylon cam into the pilaster portion of the hinge bracket assembly. See figure B. The cam should be set to same desired position on upper and lower hinge assemblies. See figure C.
- D. Connect top and bottom hinge pilaster bracket to door & hinge. Insert with hinge pin through the top and bottom of the door until the pin is flush with the door edge.
- E. With hinges in place, position door so that the upper portion of hinge bracket is on pilaster at desired height.
- F. Secure top & bottom hinge pilaster bracket to pilaster with two through bolts.
- G. Install balance of hardware per this diagram.

Inswing Door Hardware Kit (P/N 8512003) Includes:
CHROME PLATED ZAMAC



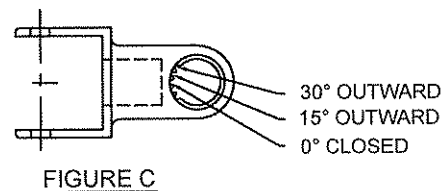
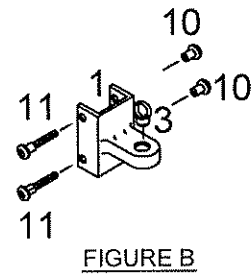
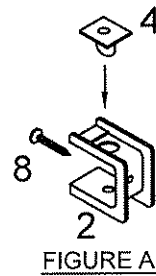
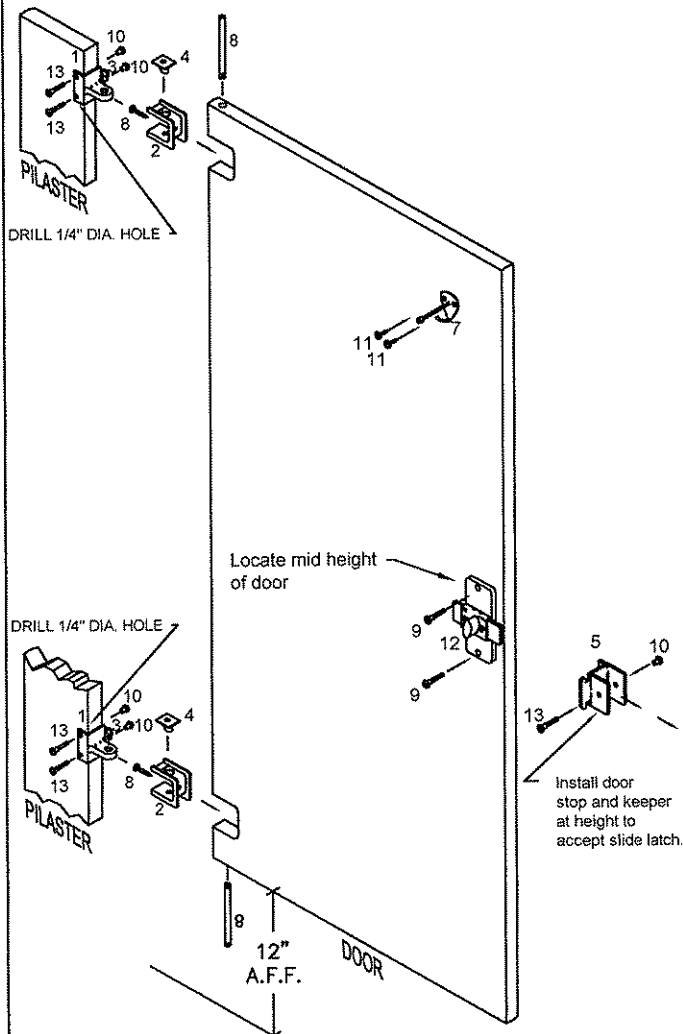

PART ID.	DESCRIPTION	QTY
1	2512800 Hinge Pilaster Bracket	(2)
2	2512810 Door hinge insert	(2)
3	6082410 Hinge Pintle Nylon	(2)
4	6082400 Hinge Cam Nylon	(2)
5	2512610 Inswing Latch Slide Keeper	(1)
6	3912420 Hinge Pin	(2)
7	2511600 Bumper And Coathook	(1)
8	3910110 Theft Resistant C/P SM #10 x 1" Flat Head	(2)
9	3910600 Theft Resistant C/P Step Bolts 1" long	(2)
10	3910690 Theft Resistant C/P 5/8" Barrel Nut	(7)
11	3912130 Theft Resistant C/P S.M.S. #10 x 5/8"	(2)
12	2513900 Slide Latch Brushed Chrome	(1)
13	3910700 Theft Resistant C/P Step Bolts 1 1/4" long	(5)

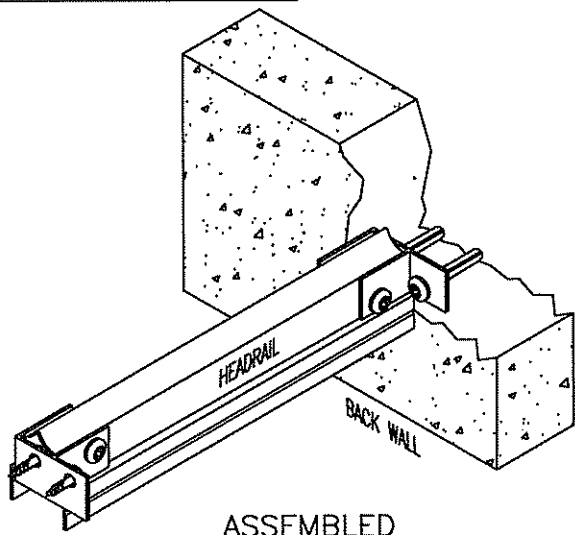

**HEADRAIL
ASSEMBLY
PLASTIC LAMINATE**





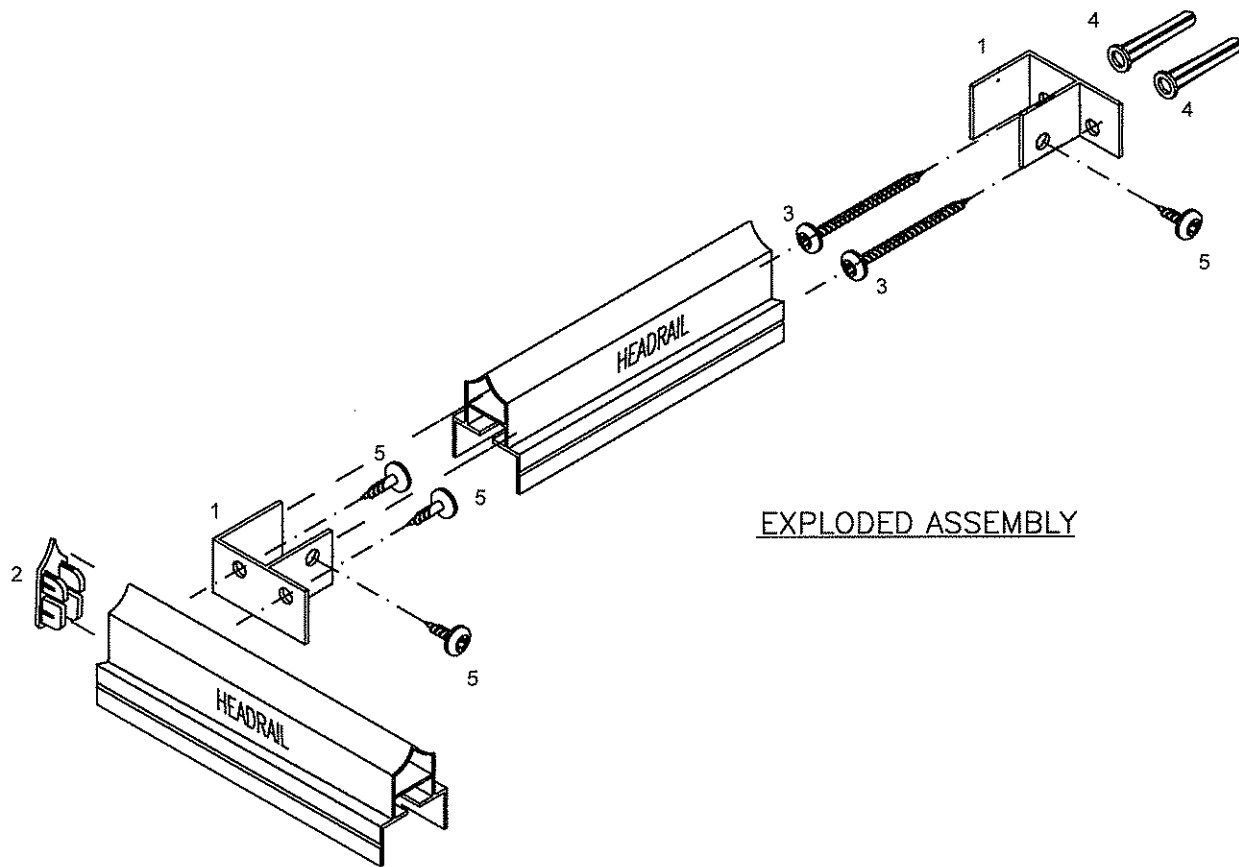

Headrail Hardware Kit (P/N 8448100) Includes:

PART ID.	DESCRIPTION	QTY
1	 2521980 Headrail Satin "F" Zamac Bracket	(2)
2	 2522200 Headrail Cap Satin Zamac	(1)
3	 3260450 Theft Resistant S/S #14 x 2 1/2" S.M.S	(2)
4	 3080000 Plastic Shield 14/16 x 1-1/2"	(2)
5	 3264120 Theft Resistant S/S #14 x 5/8" S.M.S	(4)



**URINAL SCREEN
ASSEMBLY
PLASTIC LAMINATE**

- A. Before proceeding, confirm that backing of wall is adequate to support and secure mounting of urinal screens. Check dwgs for layout.
- B. Insert anchoring devices in walls and secure wall brackets with 2 1/2" sheet metal screws.
- C. Place urinal screen on a support, 12" above the floor.
- D. Set U/S into wall brackets and fasten with recommended fasteners.

Urinal Screen Hardware Kit (P/N 8511281) Includes: CHROME PLATED ZAMAC		
PART ID.	DESCRIPTION	QTY
1	 2511280 Two Ear Wall U/S Bracket	(2)
2	 3910450 Theft Resistant C/P #14 x 2 1/2" S.M.S	(4)
3	 3080000 Plastic Shields	(4)
4	 3914120 Theft Resistant C/P #14 x 5/8" S.M.S	(8)

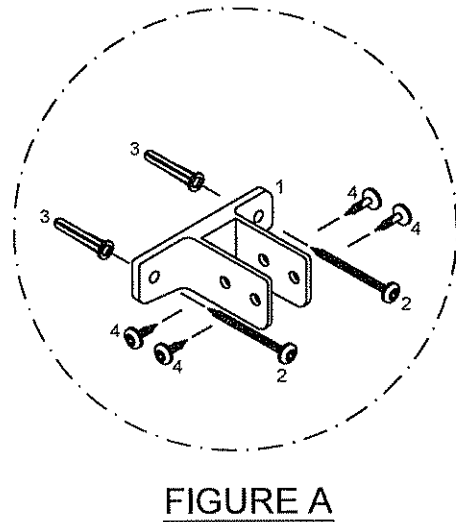
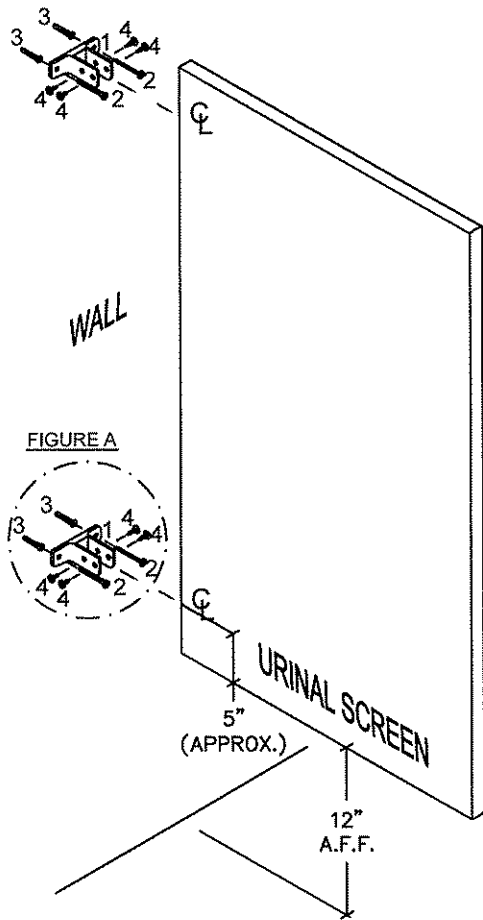

STEP 1

LAYOUT

FLOOR ANCHORED

FIGURE 1

NOTE: FLOOR MUST BE CONCRETE.

- Review the layout drawings and package lists that have accompanied this job.
- Before proceeding, confirm that backing of walls and floor is adequate to support secure mounting of the toilet compartment units.
- Establish and mark pilaster center line from back wall.
- Establish and mark panel center lines for wall brackets.
- Establish pilaster floor fastener locations from side wall according to shop drawings. (Note: Floor fasteners are located 1" from edge of pilaster).
- Mark wall bracket holes using brackets as templates.

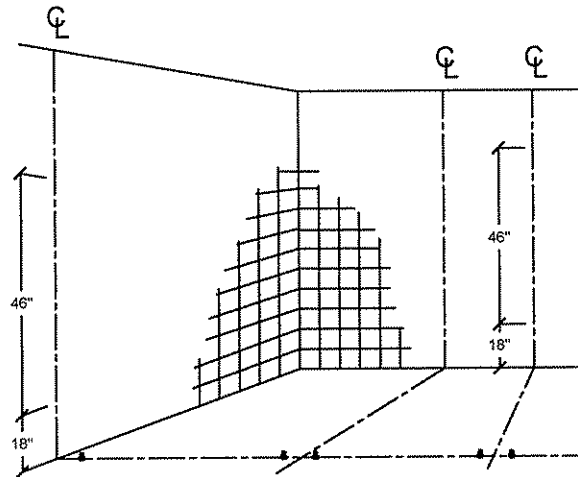

STEP 2

WALL BRACKETS AND FLOOR BRACKETS

FIGURE 2

- Drill holes for wall brackets and floor fastenings of appropriate size for particular fastening devices supplied.
- Insert anchoring devices in walls and secure wall brackets.
- Install wedge anchor with shoe clip washer and nut into concrete floor and tighten.

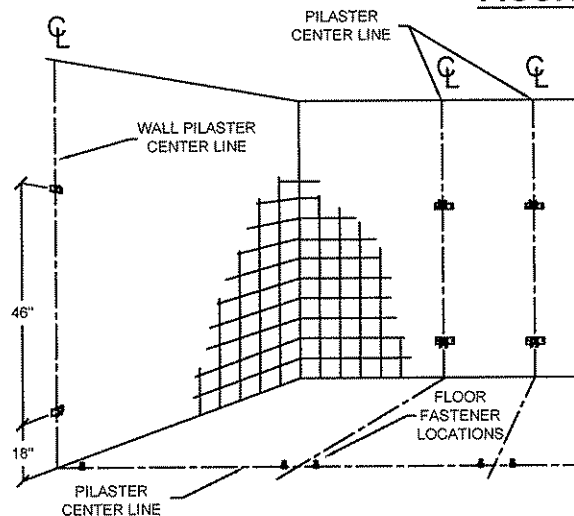

STEP 3

POSITION PANEL

FIGURE 3

- Place panel on a support, 12" above the floor.
- Set it into wall brackets, but do not fasten panel at this time.

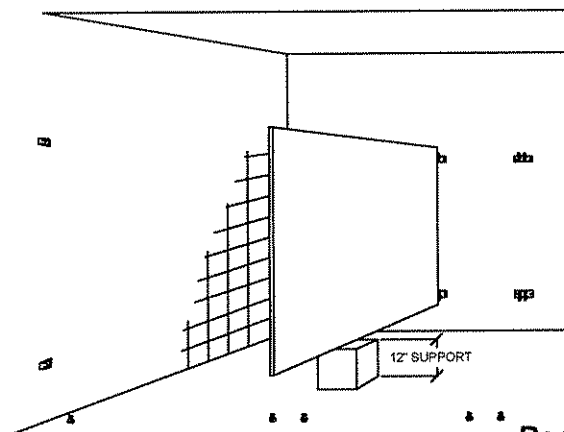

STEP 4 PILASTER PREPARATION FLOOR ANCHORED

- A. Align U-brackets in position on rear of pilasters. Refer to layout drawings.
- B. Fasten U-brackets to pilaster with sheet metal screws.
- C. Pilasters at wall do not require U-brackets, but should be prepared for wall and floor fastening as required by compartment layout.

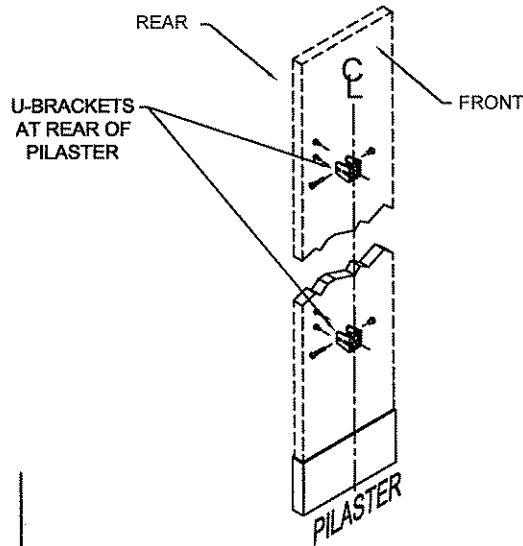
FIGURE 4

STEP 5 INSTALL PILASTERS

- A. On each wedge anchor thread place one shoe clip and 3/8" support nut down to approximately 1" up from floor level and place round washer over each anchor.
- B. Slide stainless steel shoe carefully over mounting end of pilaster and leave approximately 5" above end.
- C. Position pilaster on anchors and secure lightly with flat washers and 3/8" locking nuts.

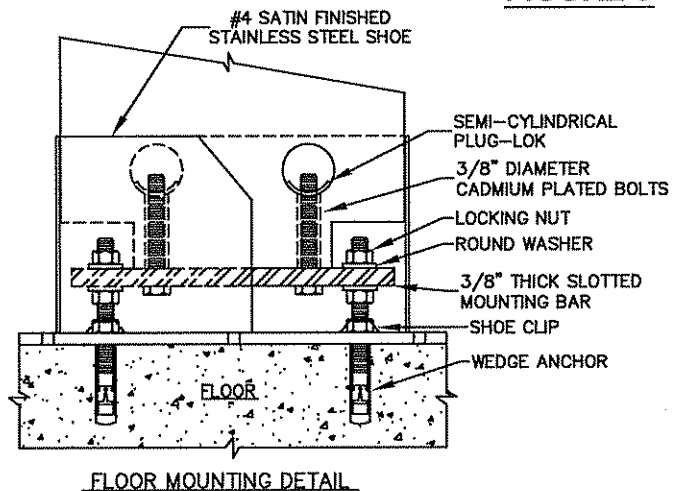
FIGURE 5

STEP 6 SECURING PILASTERS /PANELS

- A. Level each pilaster by adjusting both support nuts to desired position.
- B. Plumb each pilaster and fasten the pilaster to panel with "U" brackets using through bolts or sheet metal screws.
- C. Establish door openings by setting pilaster mounting bar to desired position on anchor.
- D. Tighten locking nuts on top of pilaster mounting bar.
- E. Slide stainless steel shoe down to floor, firmly engaging shoe clips.
- F. Fasten panel to wall brackets using through bolts.
- G. Remove panel support device.

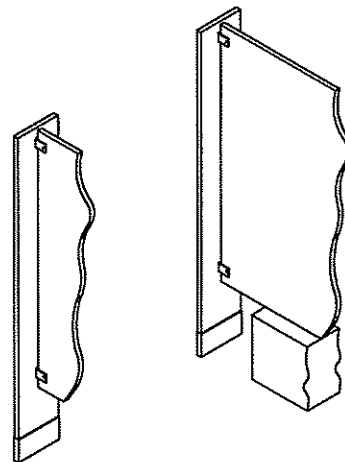







FIGURE 6

**FLOOR ANCHORED
PANEL TO PILASTER/WALL
TWO EAR ASSEMBLY
PLASTIC LAMINATE**

Pilasters must be both plumb and level.
Refer to step 4 & 6.

A. Plumb panel & fasten panel to 2-Ear bracket
at wall with through bolts.

B. Fasten pilaster to panel using through bolts
or sheet metal screws to "U" brackets.

Panel Hardware Kit (P/N 8515020) Includes: CHROME PLATED ZAMAC		
PART ID.	DESCRIPTION	QTY
1	 2511750 Two Ear Bracket	(2)
2	 2511910 "U" Bracket	(2)
3	 3910600 Theft Resistant C/P Step Bolts 1" Long	(4)
4	 3910690 Theft Resistant C/P Barrel Nut	(4)
5	 3910450 Theft Resistant C/P #14 x 2 1/2" S.M.S	(4)
6	 3080000 Plastic Shields	(4)
7	 3914120 Theft Resistant C/P #14 x 5/8" S.M.S	(12)

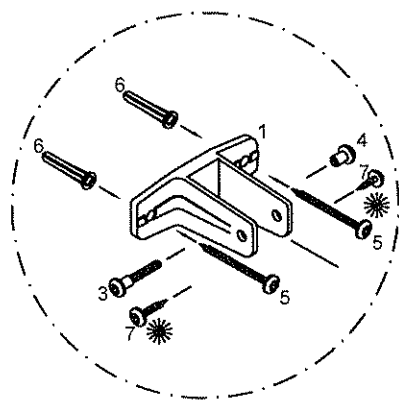
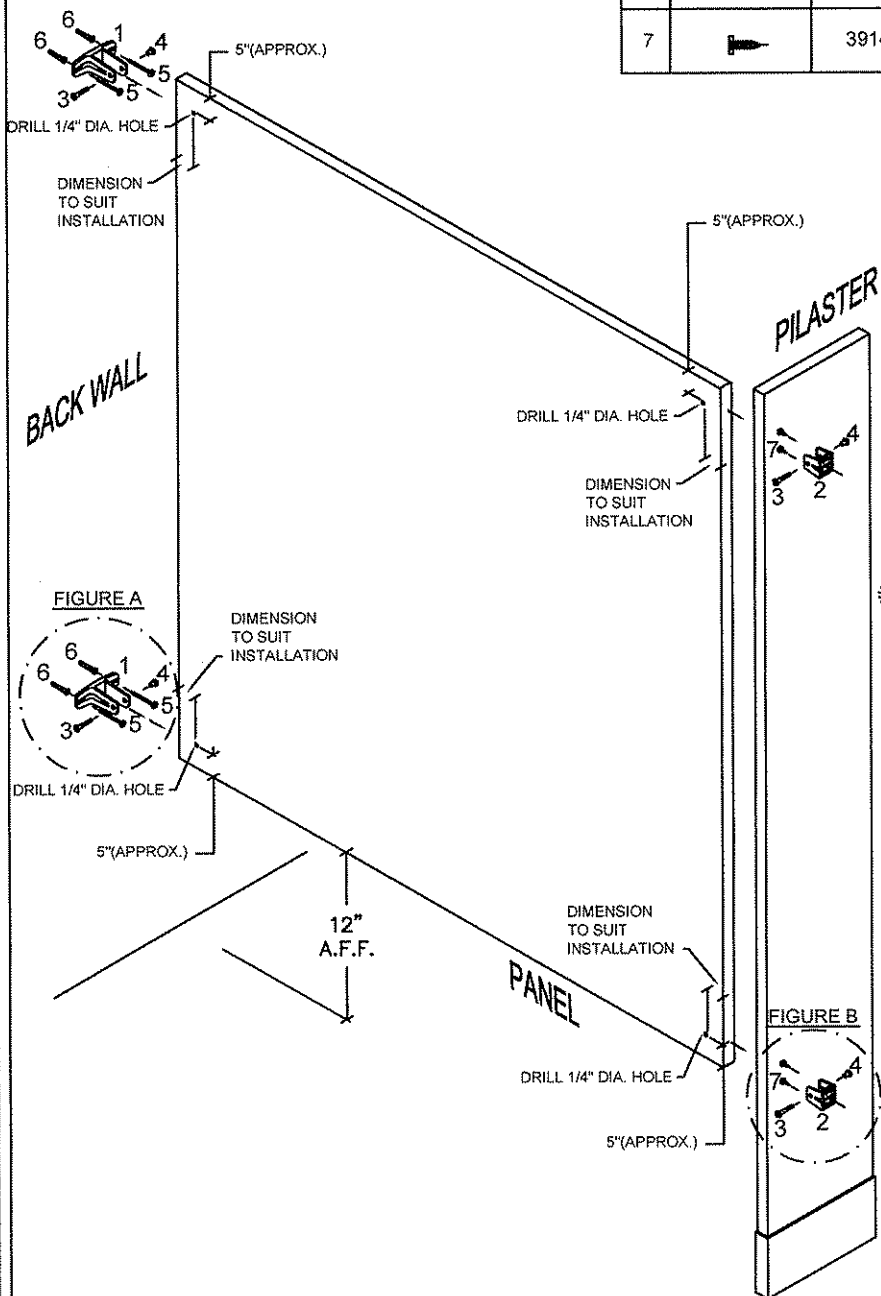

FIGURE A

※ **OPTIONAL**
Two #3914120 Theft resistant C/P #14 X 5/8"
May be Used (But Not Recommended)
To Fasten brackets To Panel.

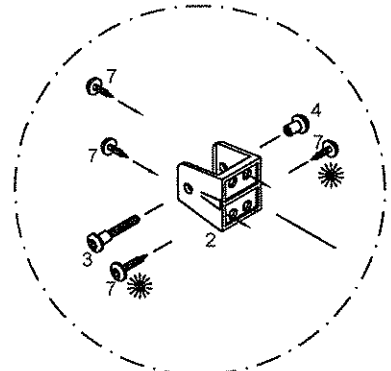









FIGURE B

NOTE:
Use Only Two #3914120
Theft resistant C/P #14 X 5/8"
To Diagonally Fasten U-bracket
To Pilaster.

**FLOOR ANCHORED
 PANEL TO PILASTER/WALL
 ONE EAR ASSEMBLY
 PLASTIC LAMINATE**

Pilasters must be both plumb and level.
 Refer to step 4 & 6.

- A. Plumb panel & fasten panel to 1-Ear bracket at wall with through bolts.
- B. Fasten pilaster to panel using through bolts or sheet metal screws to "U" brackets.

Panel Hardware Kit (P/N 8515010) includes: CHROME PLATED ZAMAC			
PART ID.		DESCRIPTION	QTY
1		2511760 One Ear Bracket	(2)
2		2511910 "U" Bracket	(2)
3		3910600 Theft Resistant C/P Step Bolts 1" Long	(4)
4		3910690 Theft Resistant C/P Barrel Nut	(4)
5		3910450 Theft Resistant C/P #14 x 2 1/2" S.M.S	(4)
6		3080000 Plastic Shields	(4)
7		3914120 Theft Resistant C/P #14 x 5/8" S.M.S	(12)

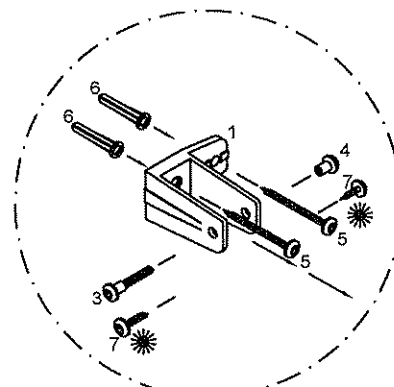
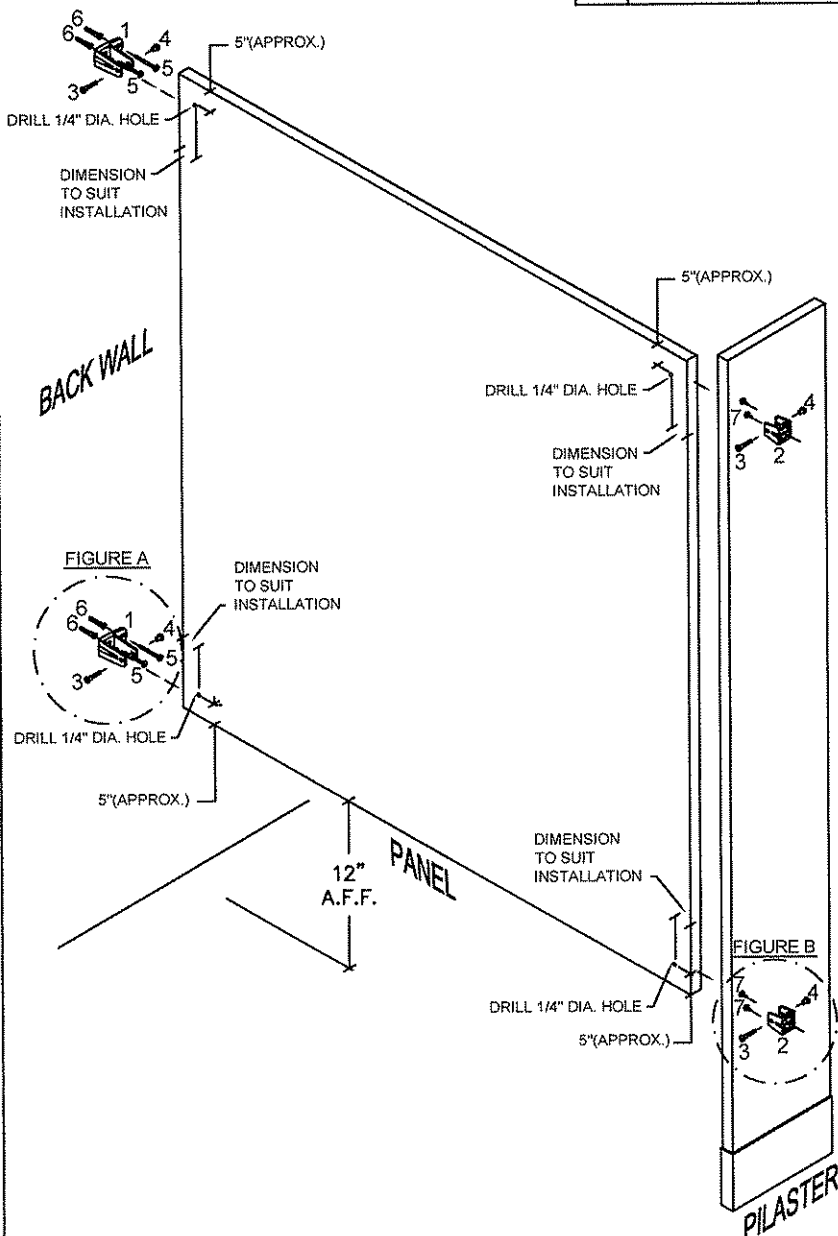
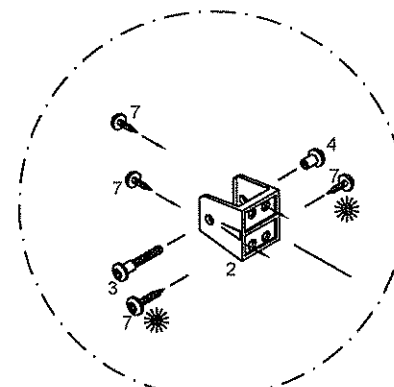

FIGURE A

☼ **OPTIONAL**
 Two #3914120 Theft resistant C/P #14 X 5/8"
 May be Used (But Not Recommended)
 To Fasten brackets To Panel.



NOTE:
 Use Only Two #3914120
 Theft resistant C/P #14 X 5/8"
 To Diagonally Fasten U-bracket To Pilaster.

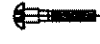



FIGURE B

**FLOOR ANCHORED
 PILASTER/WALL ASSEMBLY
 PLASTIC LAMINATE**

Pilasters must be both plumb and level.

- A. Fasten pilaster to wall bracket using through bolts or sheet metal screws.
- B. Establish door openings by adjusting pilaster mounting bar to desired positions & tighten nuts. Refer to step 6.

Pilaster/Wall Hardware Kit (P/N 8515210) includes:
 CHROME PLATED ZAMAC

PART ID.	DESCRIPTION	QTY
1	 2511840 One Ear Wall Bracket	(2)
2	 3910700 Theft Resistant C/P Step Bolts 1 1/4" Long	(2)
3	 3910690 Theft Resistant C/P Barrel Nut	(2)
4	 3910450 Theft Resistant C/P #14 x 2 1/2" S.M.S	(4)
5	 3080000 Plastic Shields	(4)
6	 3914120 Theft Resistant C/P #14 x 5/8" S.M.S	(8)

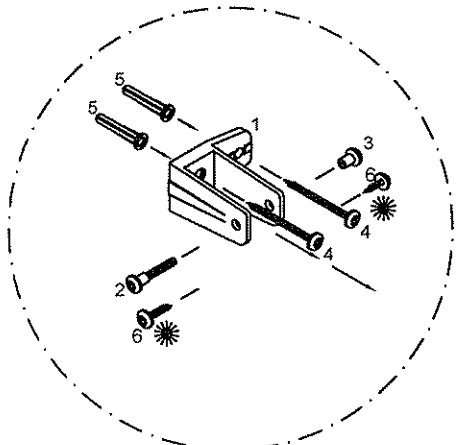
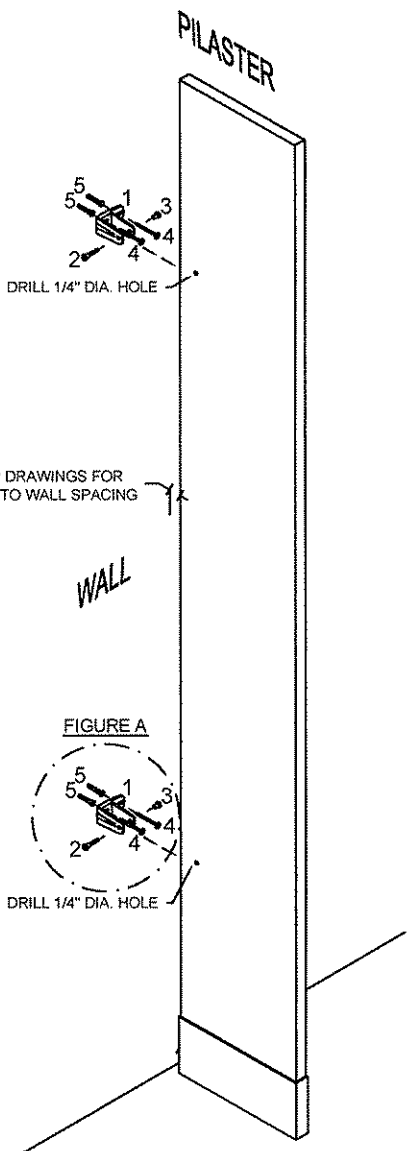
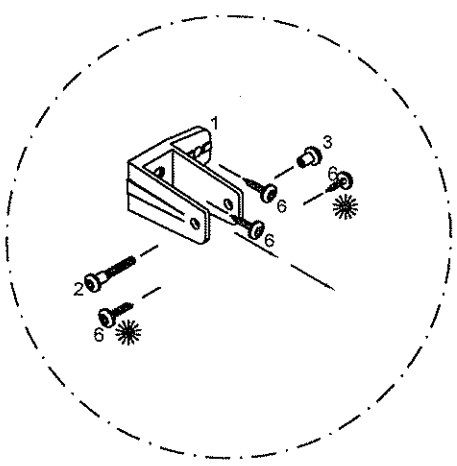

FIGURE A

☼ **OPTIONAL**
 Two #3914120 Theft resistant C/P #14 X 5/8"
 May be Used (But Not Recommended)
 To Fasten brackets To Panel.















NOTE:
 Replace #3910450 Theft Resistant C/P #14 x 2 1/2"
 With #3914120 Theft resistant C/P #14 X 5/8"
 To Fasten Pilaster To Panel.

FIGURE B

**FLOOR ANCHORED
 PILASTER/PANEL ALCOVE ASSEMBLY
 PLASTIC LAMINATE**

Note:
 Replace P/N#8515010 with P/N#8515020
 for two ear locations.

Panel Hardware Kit (P/N 8515010) Includes: CHROME PLATED ZAMAC		
PART ID.	DESCRIPTION	QTY
1	 2511760 One Ear Bracket	(2)
2	 2511910 "U" Bracket	(2)
3	 3910600 Theft Resistant C/P Step Bolts 1" Long	(4)
4	 3910690 Theft Resistant C/P Barrel Nut	(4)
5	 3910450 Theft Resistant C/P #14 x 2 1/2" S.M.S	(4)
6	 3080000 Plastic Shields	(4)
7	 3914120 Theft Resistant C/P #14 x 5/8" S.M.S	(12)
Pilaster/Wall Hardware Kit (P/N 8515210) Includes: CHROME PLATED ZAMAC		
PART ID.	DESCRIPTION	QTY
1	 2511840 One Ear Wall Bracket	(2)
2	 3910700 Theft Resistant C/P Step Bolts 1 1/4" Long	(2)
3	 3910690 Theft Resistant C/P Barrel Nut	(2)
4	 3910450 Theft Resistant C/P #14 x 2 1/2" S.M.S	(4)
5	 3080000 Plastic Shields	(4)
6	 3914120 Theft Resistant C/P #14 x 5/8" S.M.S	(8)

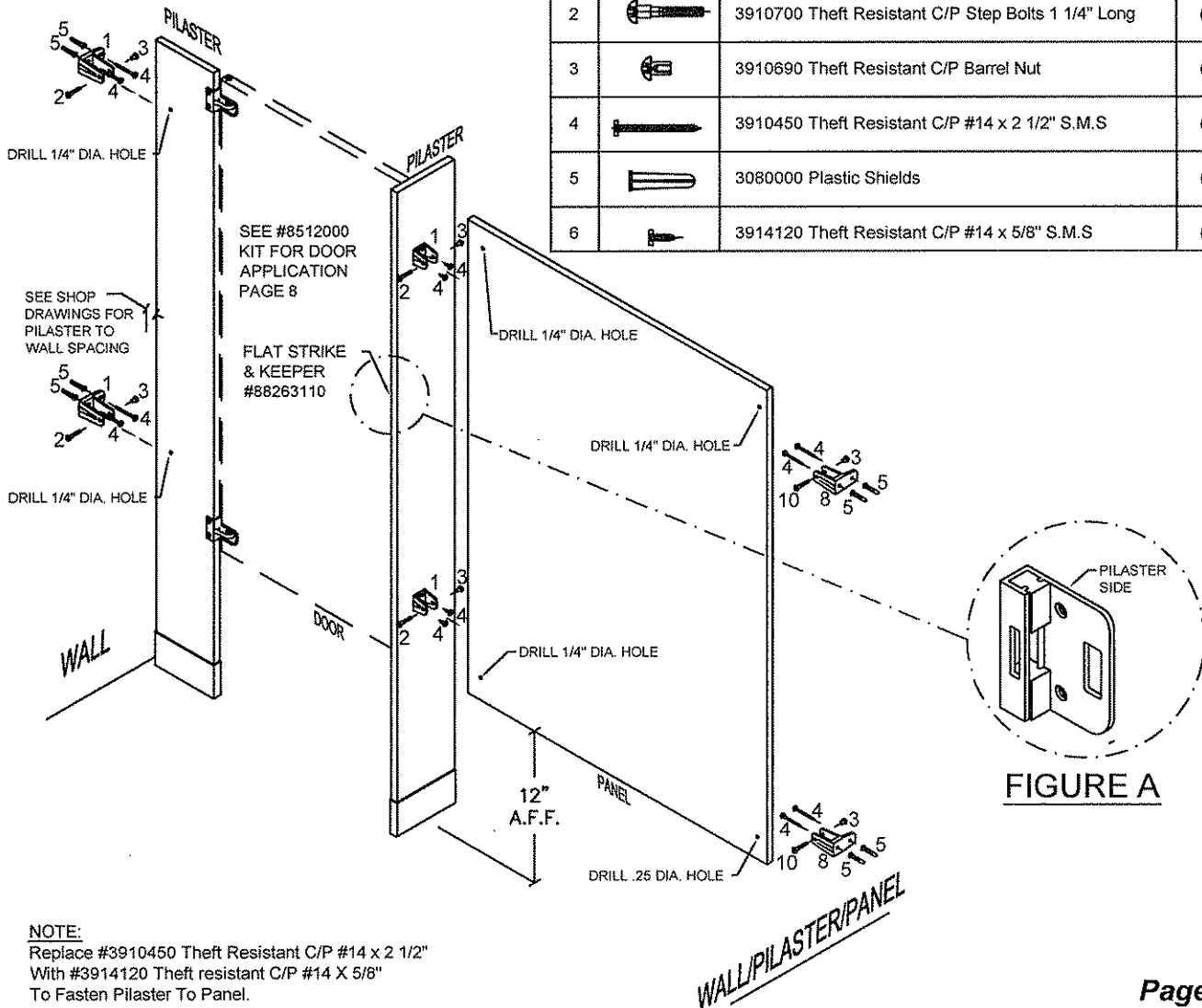
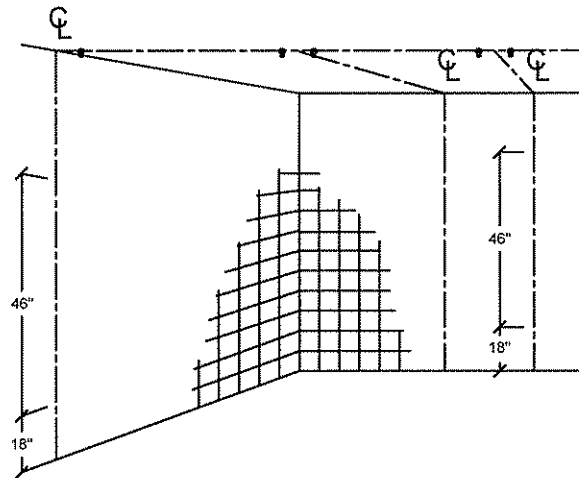

FIGURE A

STEP 1 LAYOUT CEILING HUNG

FIGURE 1

- Review the layout drawings and package lists that have accompanied this job.
- Before proceeding, confirm that backing of wall and ceiling is adequate to support secure mounting of toilet compartment units.
- Confirm correct location and condition of threaded ceiling rods. These should project 2" to 2-1/2" below finished ceiling.
- Establish and mark pilaster and panel center lines in relation to ceiling rod locations and drawings.
- Mark wall bracket holes using brackets as templates.



STEP 2 WALL BRACKETS

FIGURE 2

- Drill holes for wall brackets of appropriate size for particular fastening devices supplied.
- Insert anchoring devices in walls and secure wall brackets.
- Pilaster at wall should be prepared for wall and ceiling fastening as required by compartment layout.

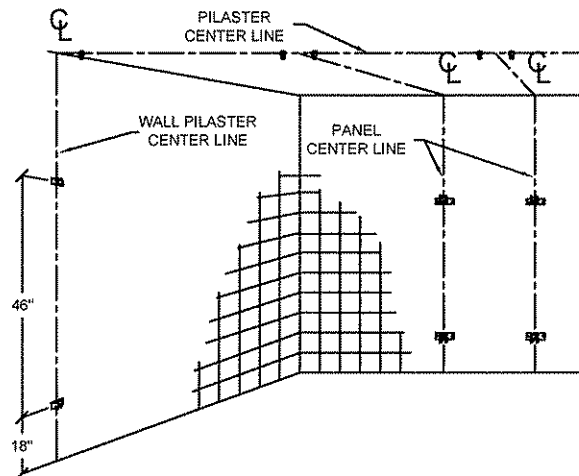

STEP 3 POSITION PANEL

FIGURE 3

- Place panel on a support, 12" above the floor.
- Set it into wall brackets, but do not fasten panel at this time.

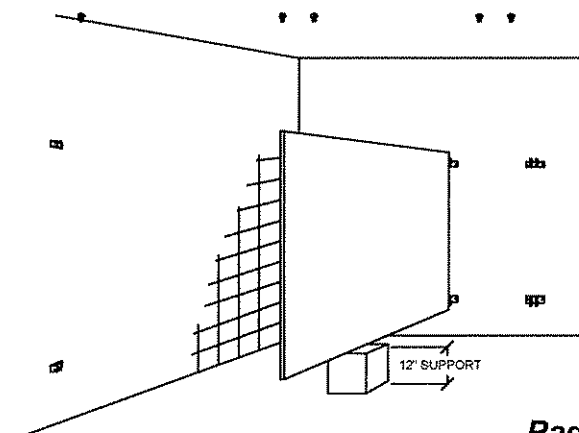

STEP 4
PILASTER PREPARATION

- A. Align U-brackets in position on rear of pilasters. Refer to layout drawings.
- B. Fasten U-brackets to pilaster with sheet metal screws.
- C. Pilasters at wall do not require U-brackets.

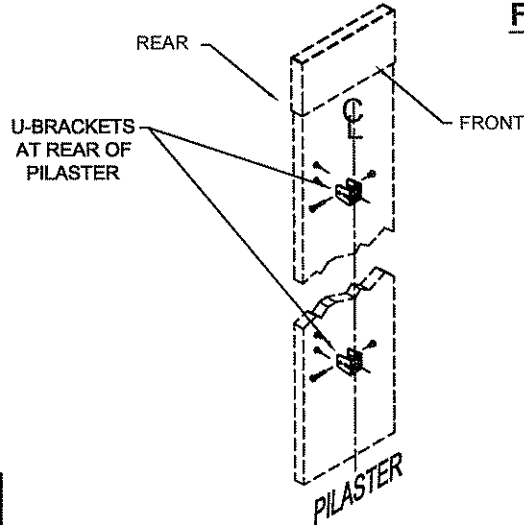
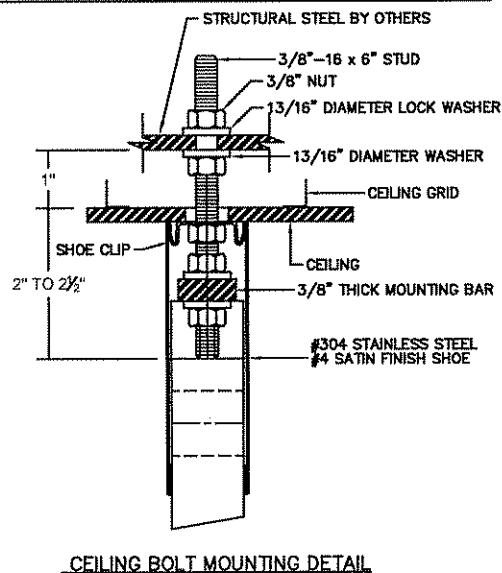

FIGURE 4

STEP 5
INSTALL PILASTERS

NOTE: STRUCTURAL STEEL BY OTHERS

- A. Place shoe clip, thread support nuts and mounting washers over threaded rods to support pilaster mounting bar.
- B. Position pilaster and mounting bar on threaded rods and attach lightly with square flat washer, lockwasher and locking nut.



STEP 6
SECURING PILASTERS TO PANELS

- A. Level each pilaster by adjusting both support nuts to desired position.
- B. Plumb each pilaster and fasten the pilaster to panel using through bolts or sheet metal screws.
- C. Establish door openings by setting pilaster mounting bar to desired position on stud.
- D. Tighten locking nuts on top of pilaster mounting bar.
- E. Slide stainless steel shoe up to ceiling, firmly engaging shoe clips.
- F. Fasten panel to wall brackets using through bolts.
- G. Remove panel support device.

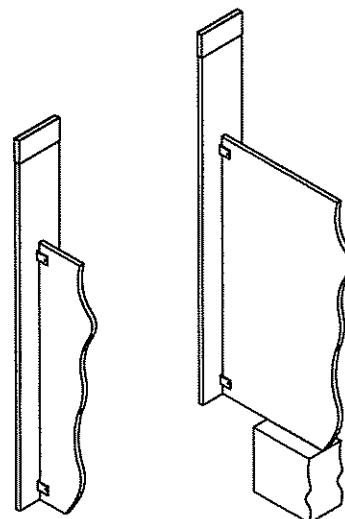









FIGURE 6

**CEILING HUNG
 PANEL TO PILASTER/WALL
 TWO EAR ASSEMBLY
 PLASTIC LAMINATE**

Pilasters must be both plumb and level.
 Refer to steps 4 & 6.

- A. Fasten panel to 2-Ear bracket at wall with through bolts.
- B. Plumb pilaster and fasten pilaster to panel using through bolts or sheet metal screws to "U" brackets.

Panel Hardware Kit (P/N 8515020) Includes: CHROME PLATED ZAMAC			
PART ID.		DESCRIPTION	QTY
1		2511750 Two Ear Bracket	(2)
2		2511910 "U" Bracket	(2)
3		3910600 Theft Resistant C/P Step Bolts 1" Long	(4)
4		3910690 Theft Resistant C/P Barrel Nut	(4)
5		3910450 Theft Resistant C/P #14 x 2 1/2" S.M.S	(4)
6		3080000 Plastic Shields	(4)
7		3914120 Theft Resistant C/P #14 x 5/8" S.M.S	(12)

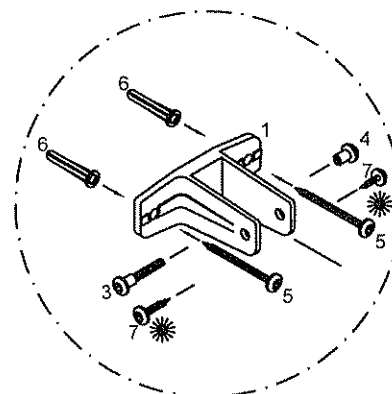
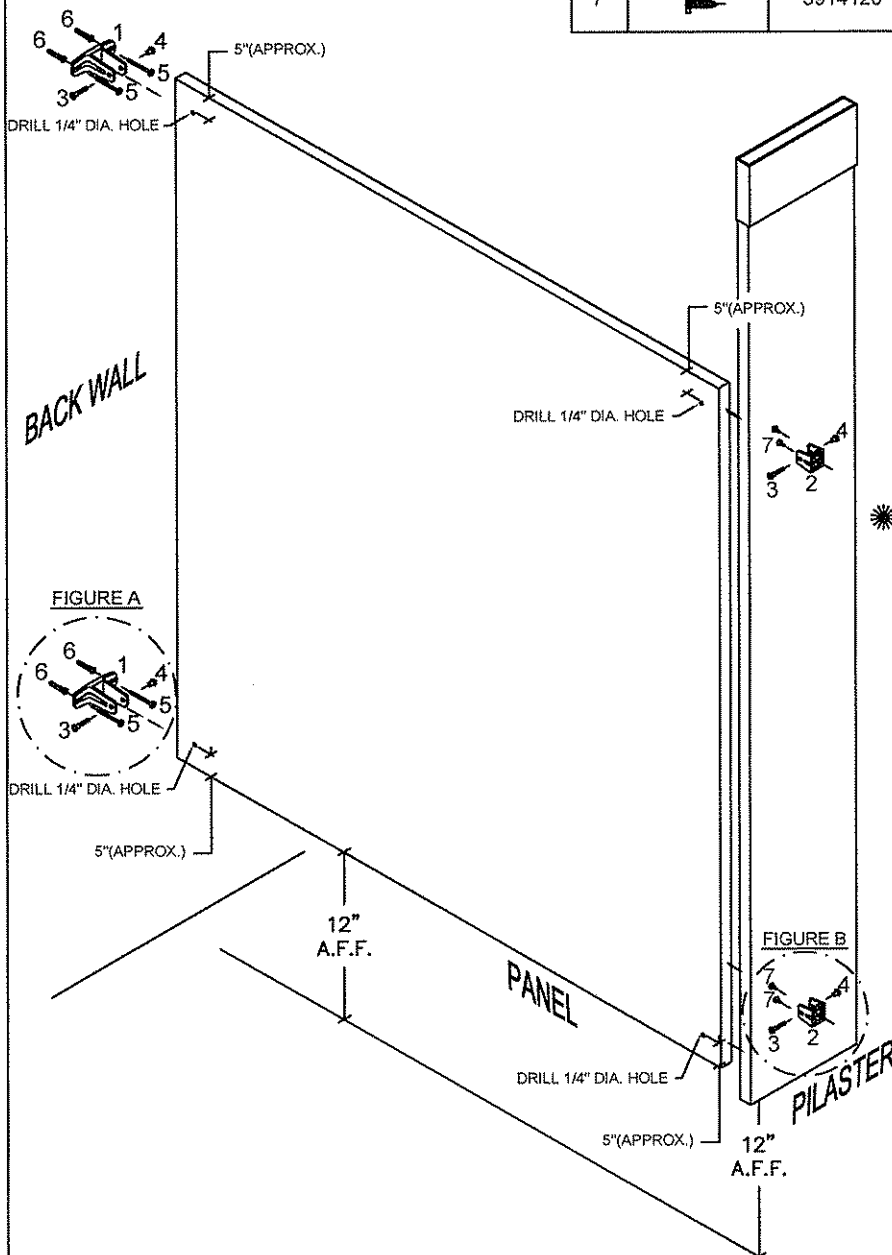
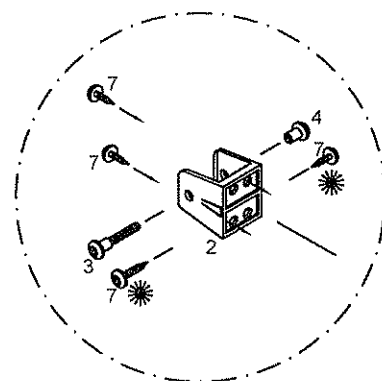

FIGURE A

✱ **OPTIONAL**
 Two #3914120 Theft resistant C/P #14 X 5/8"
 May be Used (But Not Recommended)
 To Fasten brackets To Panel.



NOTE:
 Use Only Two #3914120
 Theft resistant C/P #14 X 5/8"
 To Diagonally Fasten U-bracket To Pilaster.







FIGURE B

**CEILING HUNG
PANEL TO PILASTER/WALL
ONE EAR ASSEMBLY
PLASTIC LAMINATE**

Pilasters must be both plumb and level.
Refer to steps 4 & 6.

A. Fasten panel to 1-Ear bracket at wall with
through bolts.

B. Plumb pilaster and fasten pilaster to panel
using through bolts or sheet metal screws
to "U" brackets.

Panel Hardware Kit (P/N 8515010) Includes: CHROME PLATED ZAMAC		
PART ID.	DESCRIPTION	QTY
1	 2511760 One Ear Bracket	(2)
2	 2511910 "U" Bracket	(2)
3	 3910600 Theft Resistant C/P Step Bolts 1" Long	(4)
4	 3910690 Theft Resistant C/P Barrel Nut	(4)
5	 3910450 Theft Resistant C/P #14 x 2 1/2" S.M.S	(4)
6	 3080000 Plastic Shields	(4)
7	 3914120 Theft Resistant C/P #14 x 5/8" S.M.S	(12)

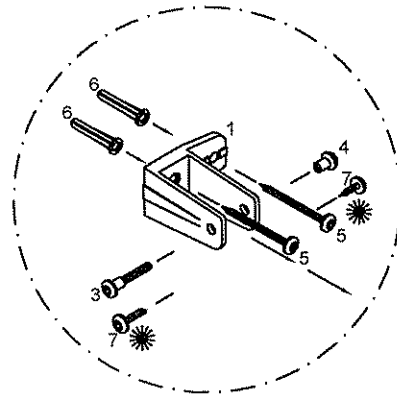
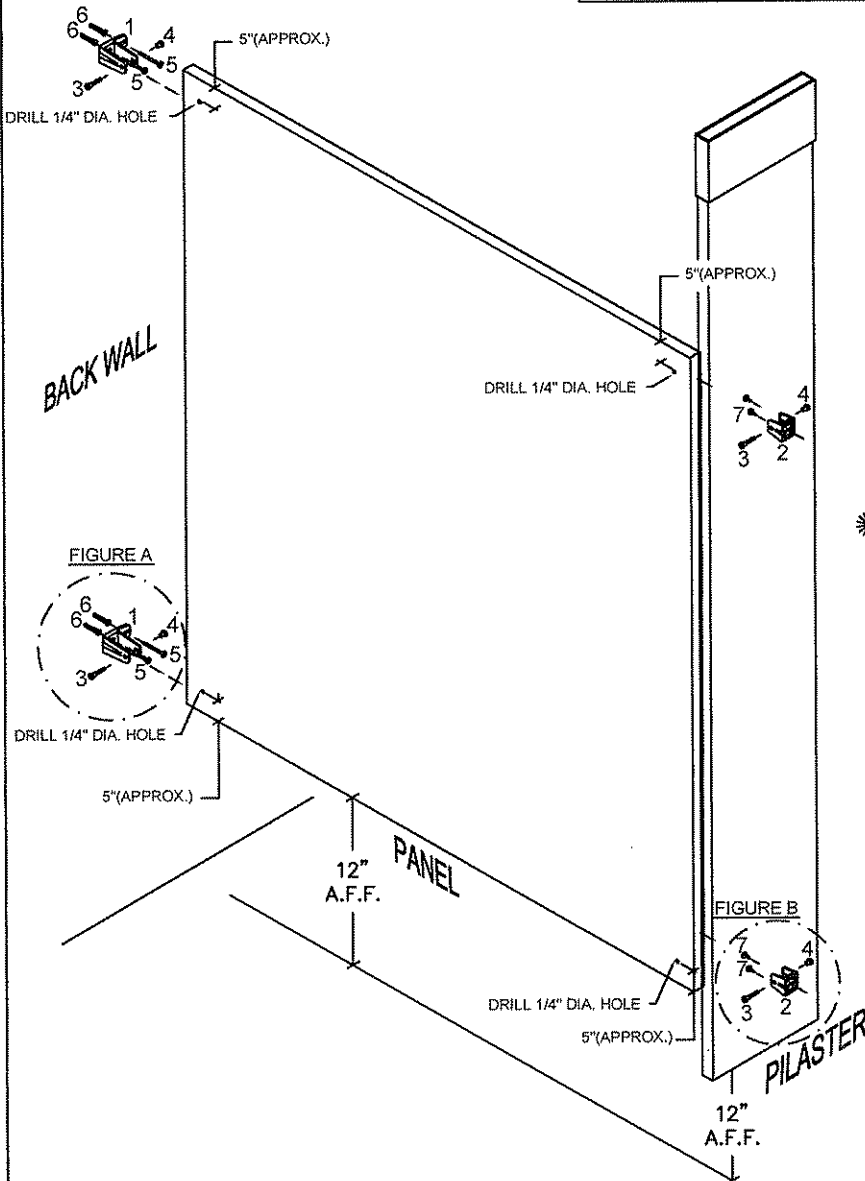
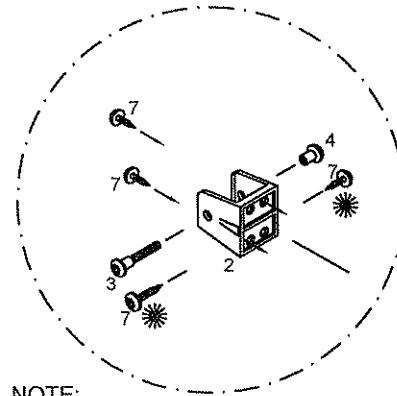

FIGURE A

☼ **OPTIONAL**
Two #3914120 Theft resistant C/P #14 X 5/8"
May be Used (But Not Recommended)
To Fasten brackets To Panel.









NOTE:
Use Only Two #3914120
Theft resistant C/P #14 X 5/8"
To Diagonally Fasten U-bracket To Pilaster.

FIGURE B

**CEILING HUNG
PILASTER/WALL
ASSEMBLY
PLASTIC LAMINATE**

Pilasters must be both plumb and level.

- A. Fasten pilaster to wall bracket using through bolts or sheet metal screws.
- B. Establish door openings by adjusting pilaster mounting bar to desired positions & tighten nuts. Refer to step 6.

Pilaster/Wall Hardware Kit (P/N 8515210) Includes: CHROME PLATED ZAMAC		
PART ID.	DESCRIPTION	QTY
1	 2511840 One Ear Wall Bracket	(2)
2	 3910700 Theft Resistant C/P Step Bolts 1 1/4" Long	(2)
3	 3910690 Theft Resistant C/P Barrel Nut	(2)
4	 3910450 Theft Resistant C/P #14 x 2 1/2" S.M.S	(4)
5	 3080000 Plastic Shields	(4)
6	 3914120 Theft Resistant C/P #14 x 5/8" S.M.S	(8)

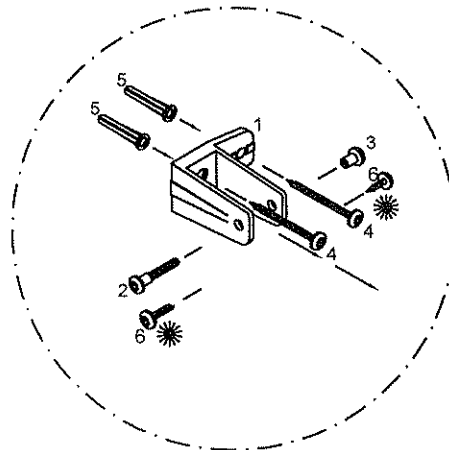
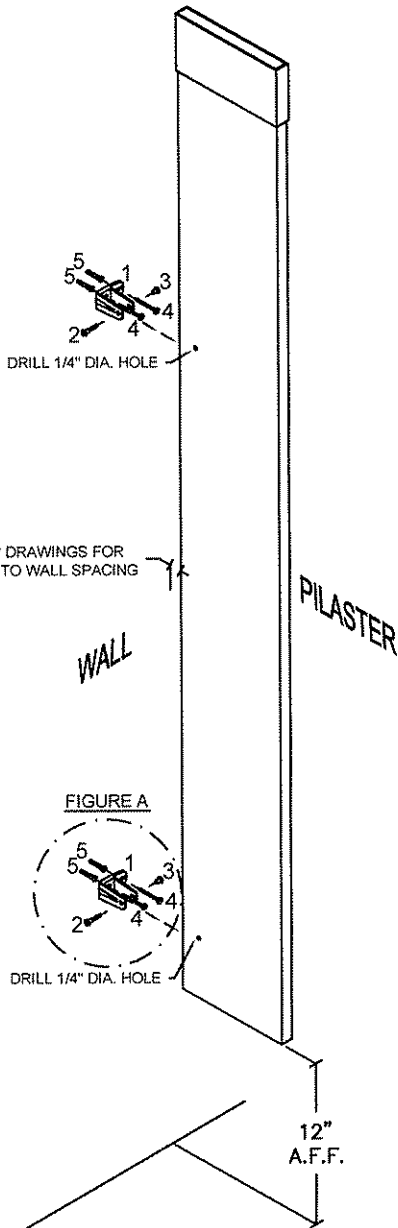
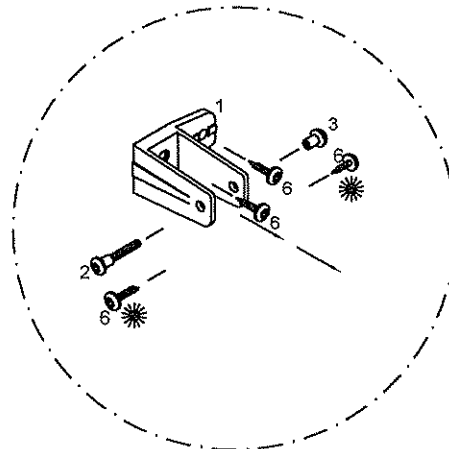

FIGURE A

☼ **OPTIONAL**
Two #3914120 Theft resistant C/P #14 X 5/8"
May be Used (But Not Recommended)
To Fasten brackets To Panel.



NOTE:
Replace #3910450 Theft Resistant C/P #14 x 2 1/2"
With #3914120 Theft resistant C/P #14 X 5/8"
To Fasten Pilaster To Panel.

FIGURE B

**CEILING HUNG
PILASTER/PANEL ALCOVE
ASSEMBLY
PLASTIC LAMINATE**

Note:
Replace P/N#8515010 with P/N#8515020
for two ear locations.

Panel Hardware Kit (P/N 8515010) Includes: CHROME PLATED ZAMAC			
PART ID.		DESCRIPTION	QTY
1		2511760 One Ear Bracket	(2)
2		2511910 "U" Bracket	(2)
3		3910600 Theft Resistant C/P Step Bolts 1" Long	(4)
4		3910690 Theft Resistant C/P Barrel Nut	(4)
5		3910450 Theft Resistant C/P #14 x 2 1/2" S.M.S	(4)
6		3080000 Plastic Shields	(4)
7		3914120 Theft Resistant C/P #14 x 5/8" S.M.S	(12)

Pilaster/Wall Hardware Kit (P/N 8515210) Includes: CHROME PLATED ZAMAC			
PART ID.		DESCRIPTION	QTY
1		2511840 One Ear Wall Bracket	(2)
2		3910700 Theft Resistant C/P Step Bolts 1 1/4" Long	(2)
3		3910690 Theft Resistant C/P Barrel Nut	(2)
4		3910450 Theft Resistant C/P #14 x 2 1/2" S.M.S	(4)
5		3080000 Plastic Shields	(4)
6		3914120 Theft Resistant C/P #14 x 5/8" S.M.S	(8)

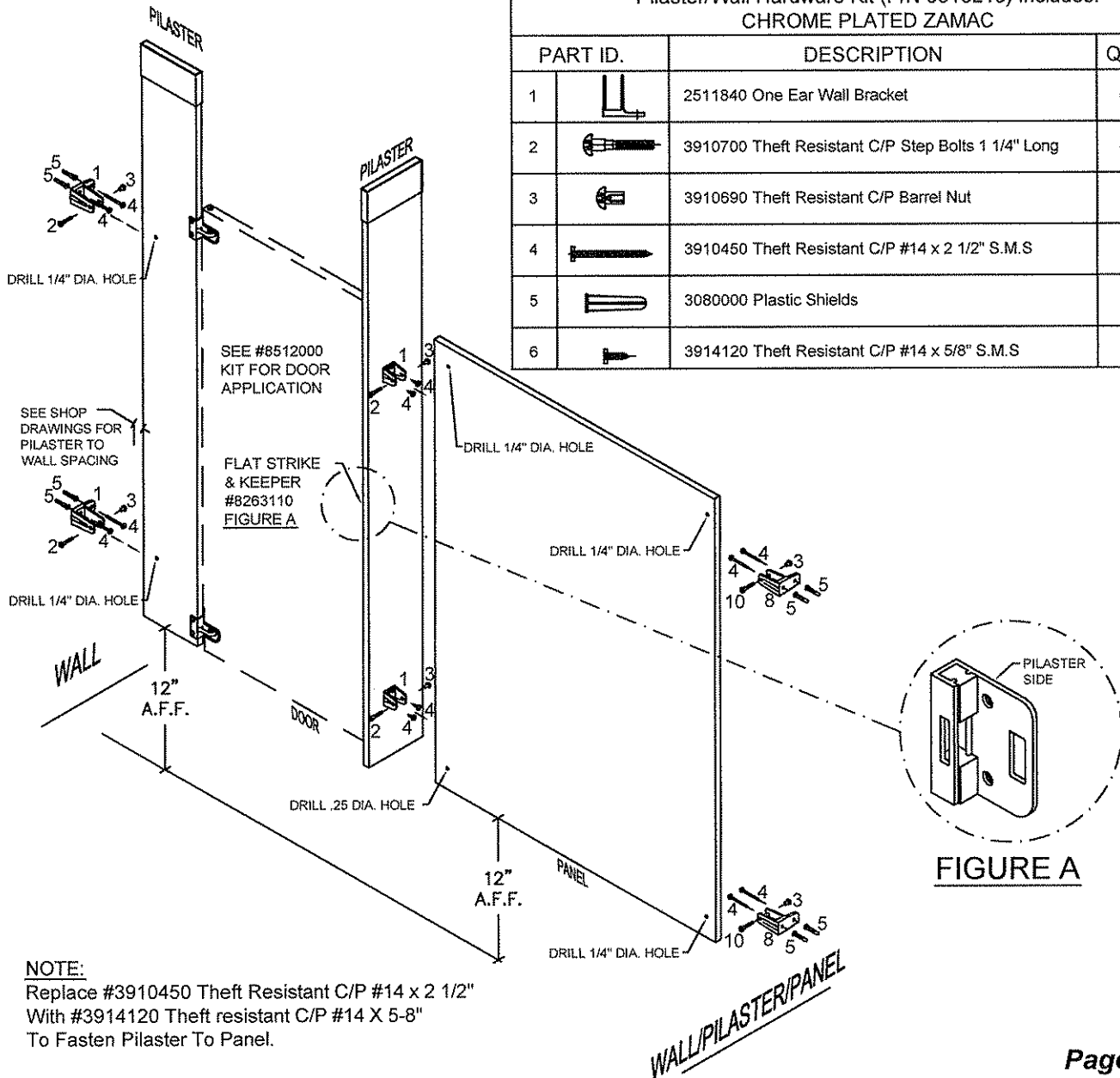

STEP 1
LAYOUT
FLOOR ANCHORED/CEILING ANCHORED

FIGURE 1

NOTE: FLOOR MUST BE CONCRETE.

- A. Review the layout drawings and package lists that have accompanied this job.
- B. Before proceeding, confirm that backing of wall and ceiling support is adequate to secure mounting of toilet compartment units.
- C. Establish and mark pilaster center line from back wall.
- D. Establish and mark panel center lines for wall brackets.
- E. Establish pilaster floor and ceiling fastener locations from side wall according to shop drawings. (Note: Fasteners are located 1" from edge of pilaster.)
- F. Mark wall bracket holes using brackets as templates.

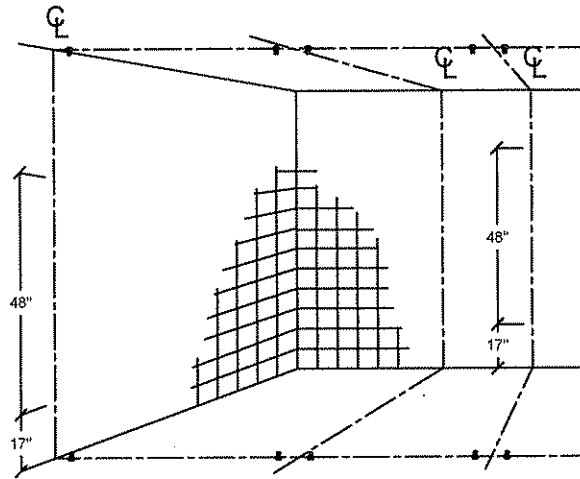

STEP 2
WALL BRACKETS AND FLOOR BRACKETS

FIGURE 2

- A. Drill holes for wall brackets and floor fastenings of appropriate size for particular fastening devices supplied.
- B. Insert anchoring devices in walls and secure wall brackets.
- C. Install wedge anchor with shoe clip, washer and nut into concrete floor and tighten.

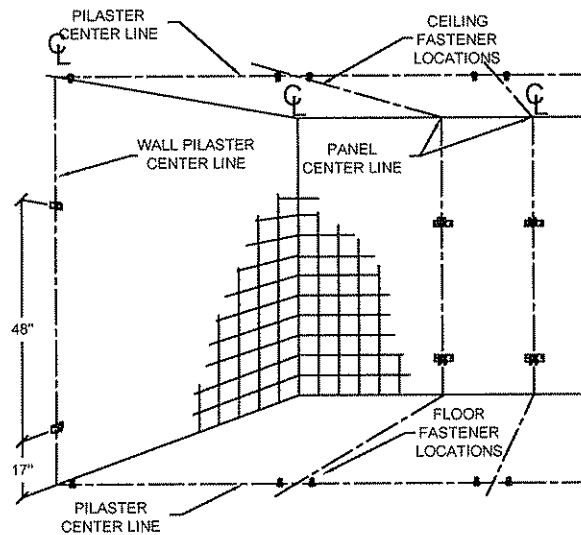

STEP 3
POSITION PANEL

FIGURE 3

- A. Place panel on a support, 12" above the floor.
- B. Set it into wall brackets, but do not fasten panel at this time.

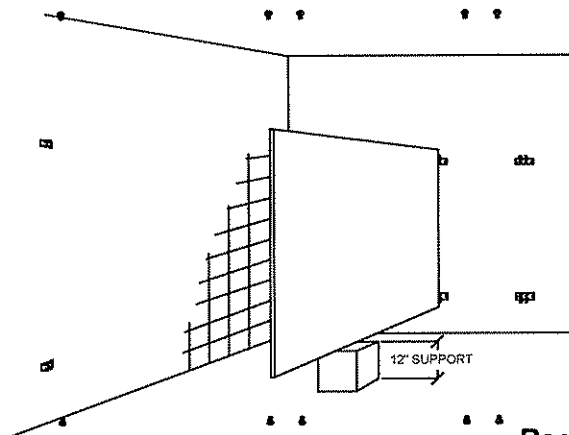

**STEP 4
 PILASTER PREPARATION**

FIGURE 4

- A. Align U-brackets in position on rear of pilasters. Refer to layout drawings.
- B. Fasten U-brackets to pilaster with sheet metal screws.
- C. Pilasters at wall do not require U-brackets, but should be prepared for wall and floor fastening as required by compartment layout.

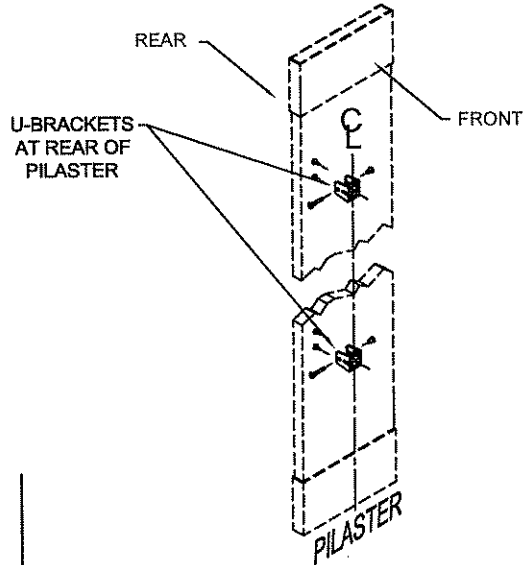

**STEP 5
 INSTALL PILASTERS**

FIGURE 5

NOTE: STRUCTURAL STEEL BY OTHERS

- A. Place shoe clip, thread support nut and mounting washers over threaded rods to support pilaster mounting bar.
- B. At the floor position pilaster and mounting bar on wedge anchors and attach lightly with square flat washer, lockwasher and locking nut.

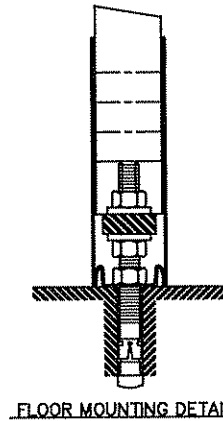
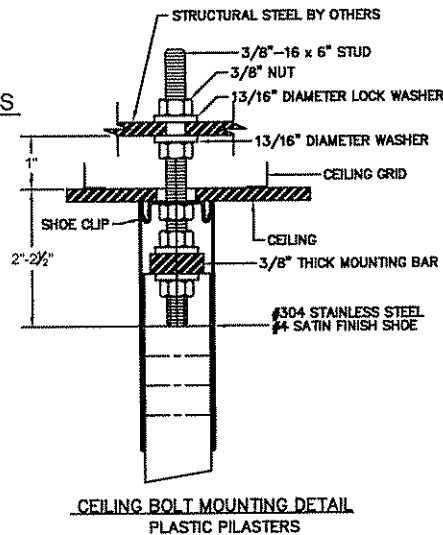

**STEP 6
 SECURING PILASTERS TO PANELS**

FIGURE 6

- A. Level each pilaster by adjusting both support nuts to desired position.
- B. Plumb each pilaster and fasten the pilaster to panel using through bolts or sheet metal screws.
- C. Establish door openings by setting pilaster mounting bar to desired position on stud.
- D. Tighten locking nuts on top of pilaster mounting bar.
- E. Slide stainless steel shoe up to ceiling and down to floor level, firmly engaging shoe clips.
- F. Fasten panel to wall brackets using through bolts.
- G. Remove panel support device.

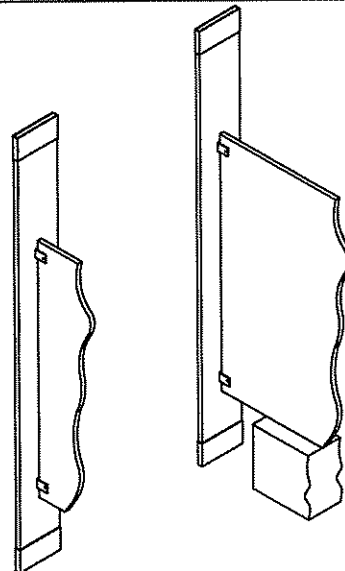







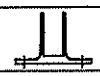
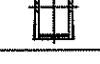

**FLOOR AND CEILING ANCHORED
PANEL TO PILASTER/WALL
TWO EAR ASSEMBLY
PLASTIC LAMINATE**

Pilasters must be both plumb and level.
Refer to steps 4 & 6.

- A. Plumb panel and fasten panel to 2 Ear bracket at wall with through bolts.
- B. Plumb pilaster and fasten pilaster to panel using through bolts or sheet metal screws to "U" brackets.

Panel Hardware Kit (P/N 8515020) includes: CHROME PLATED ZAMAC		
PART ID.	DESCRIPTION	QTY
1	 2511750 Two Ear Bracket	(2)
2	 2511910 "U" Bracket	(2)
3	 3910600 Theft Resistant C/P Step Bolts 1" Long	(4)
4	 3910690 Theft Resistant C/P Barrel Nut	(4)
5	 3910450 Theft Resistant C/P #14 x 2 1/2" S.M.S	(4)
6	 3080000 Plastic Shields	(4)
7	 3914120 Theft Resistant C/P #14 x 5/8" S.M.S	(12)

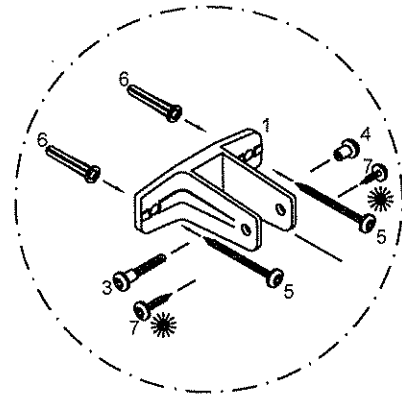
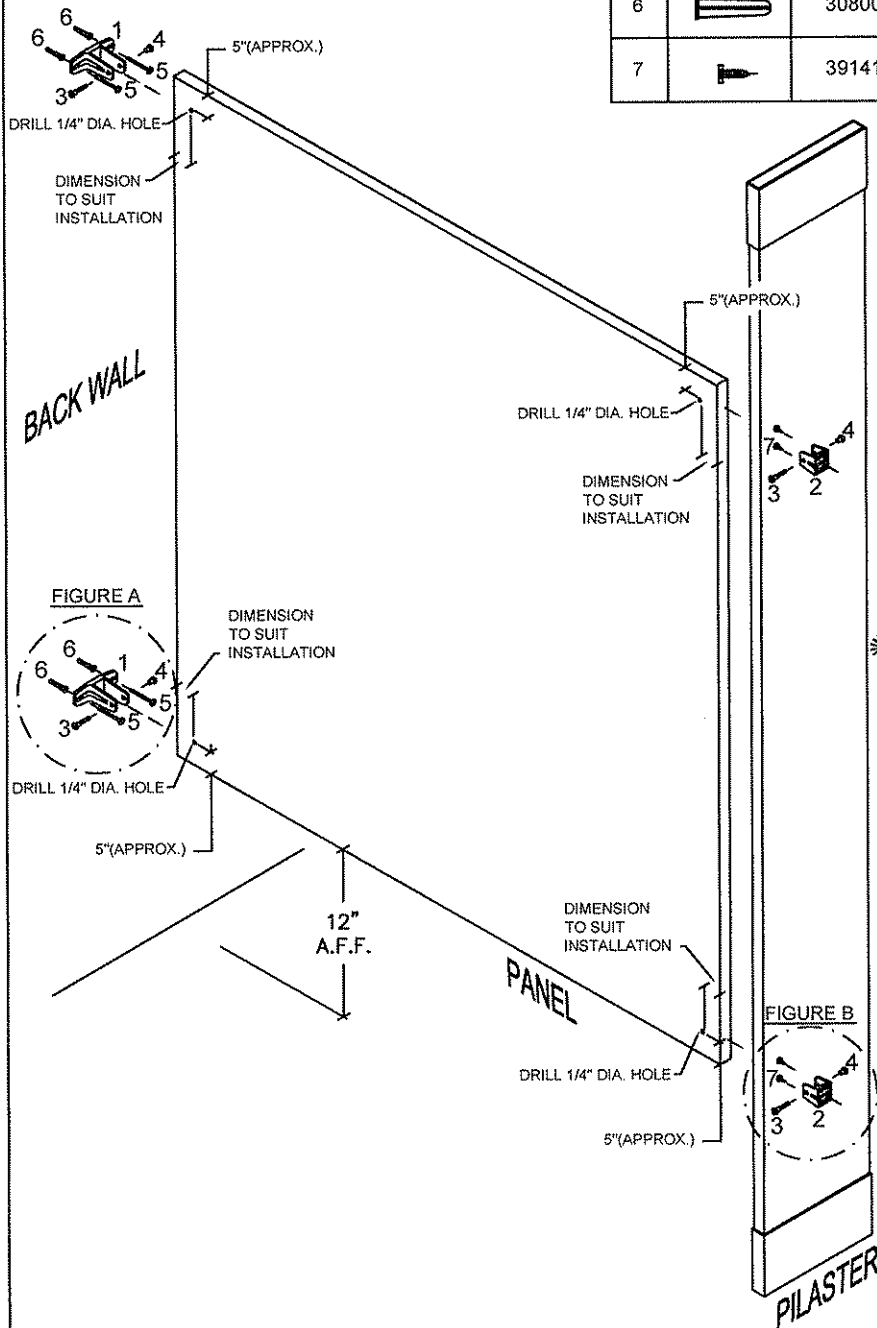

FIGURE A

OPTIONAL
Two #3914120 Theft resistant C/P #14 X 5/8"
May be Used (But Not Recommended)
To Fasten brackets To Panel.

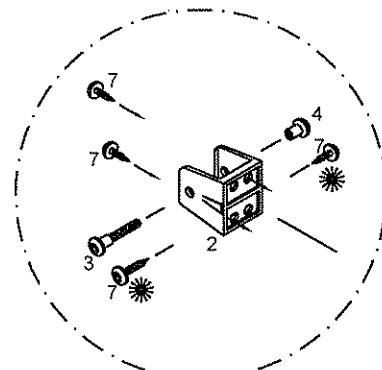









FIGURE B

NOTE:
Use Only Two #3914120
Theft resistant C/P #14 X 5/8"
To Diagonally Fasten U-bracket To Pilaster.

**FLOOR AND CEILING ANCHORED
PANEL TO PILASTER/WALL
ONE EAR ASSEMBLY
PLASTIC LAMINATE**

Pilasters must be both plumb and level.
Refer to steps 4 & 6.

- A. Plumb panel and fasten panel to 1 Ear bracket at wall with through bolts.
- B. Plumb pilaster and fasten pilaster to panel using through bolts or sheet metal screws to "U" brackets.

Panel Hardware Kit (P/N 8515010) Includes: CHROME PLATED ZAMAC			
PART ID.		DESCRIPTION	QTY
1		2511760 One Ear Bracket	(2)
2		2511910 "U" Bracket	(2)
3		3910600 Theft Resistant C/P Step Bolts 1" Long	(4)
4		3910690 Theft Resistant C/P Barrel Nut	(4)
5		3910450 Theft Resistant C/P #14 x 2 1/2" S.M.S	(4)
6		3080000 Plastic Shields	(4)
7		3914120 Theft Resistant C/P #14 x 5/8" S.M.S	(12)

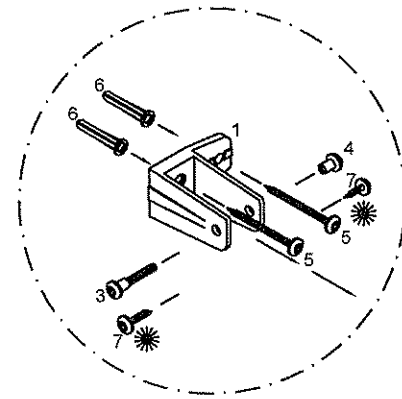
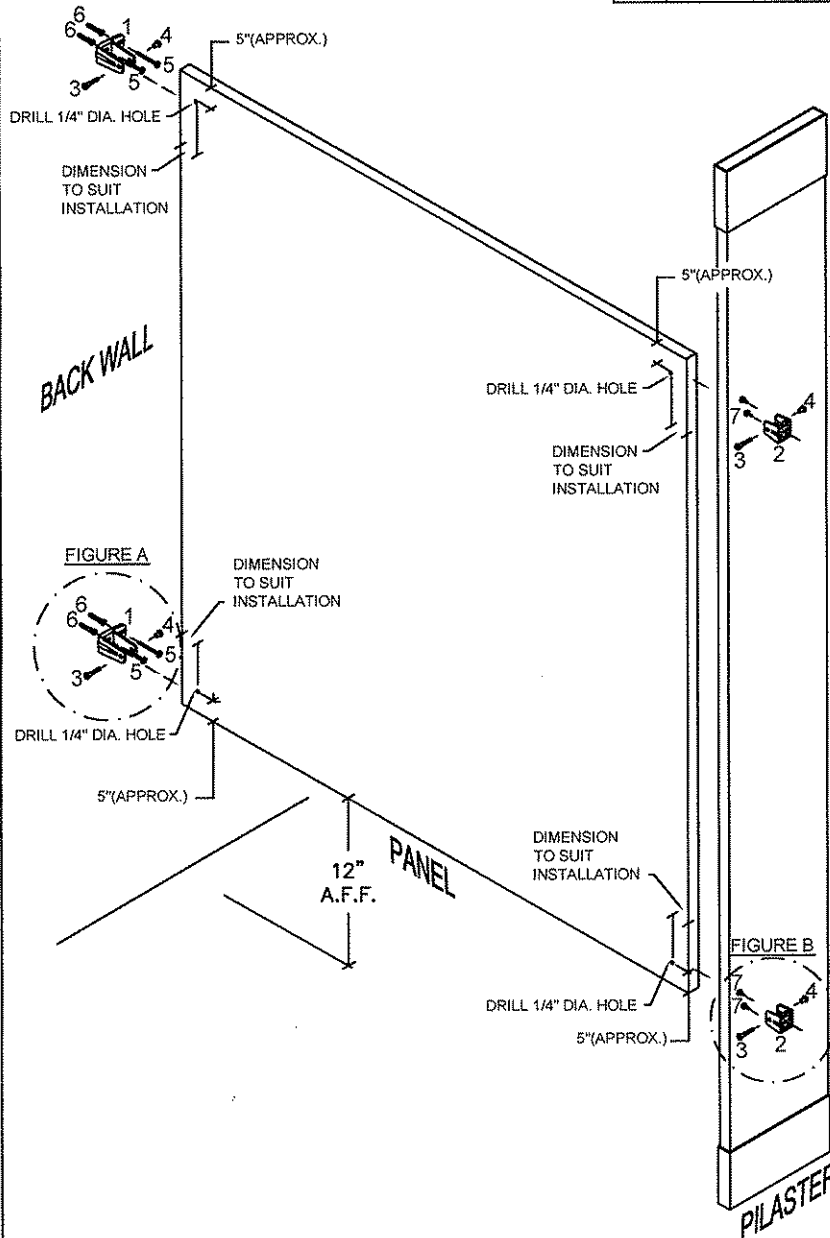

FIGURE A

OPTIONAL
Two #3914120 Theft resistant C/P #14 X 5/8"
May be Used (But Not Recommended)
To Fasten brackets To Panel.

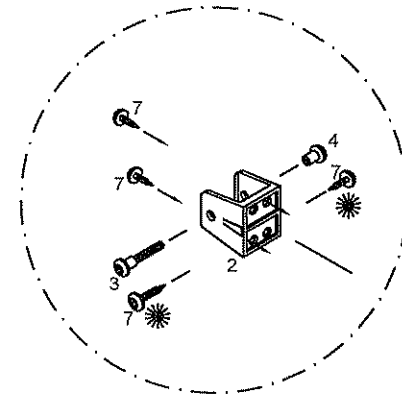







FIGURE B

NOTE:
Use Only Two #3914120 Theft resistant C/P #14 X 5/8"
To Diagonally Fasten U-bracket To Pilaster.

**FLOOR AND CEILING ANCHORED
PILASTER/WALL
ASSEMBLY
PLASTIC LAMINATE**

Pilasters must be both plumb and level.

- A. Fasten pilaster to wall bracket using through bolts or sheet metal screws.
- B. Establish door openings by adjusting pilaster mounting bar to desired positions & tighten nuts. Refer to step 6.

Pilaster/Wall Hardware Kit (P/N 8515210) Includes: CHROME PLATED ZAMAC			
PART ID.		DESCRIPTION	QTY
1		2511840 One Ear Wall Bracket	(2)
2		3910700 Theft Resistant C/P Step Bolts 1 1/4" Long	(2)
3		3910690 Theft Resistant C/P Barrel Nut	(2)
4		3910450 Theft Resistant C/P #14 x 2 1/2" S.M.S	(4)
5		3080000 Plastic Shields	(4)
6		3914120 Theft Resistant C/P #14 x 5/8" S.M.S	(8)

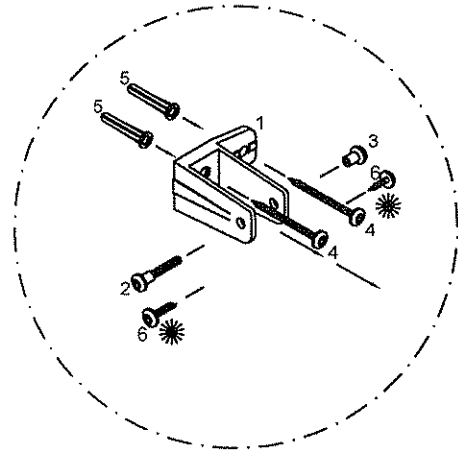
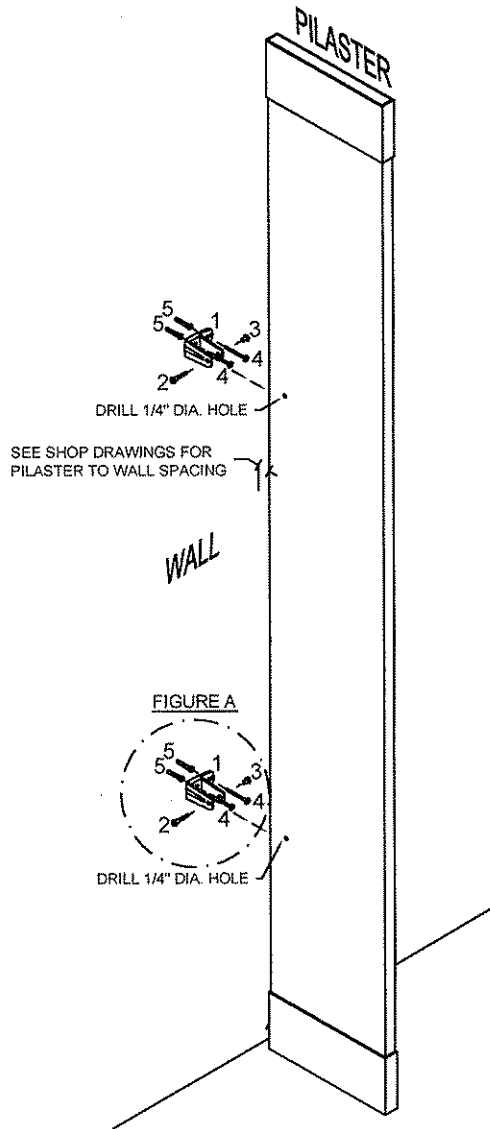
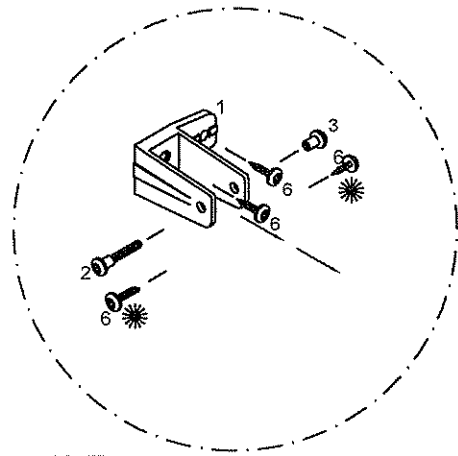

FIGURE A

☼ **OPTIONAL**
Two #3914120 Theft resistant C/P #14 X 5/8"
May be Used (But Not Recommended)
To Fasten brackets To Panel.













NOTE:
Replace #3910450 Theft Resistant C/P #14 x 2 1/2"
With #3914120 Theft resistant C/P #14 X 5/8"
To Fasten Pilaster To Panel.

FIGURE B



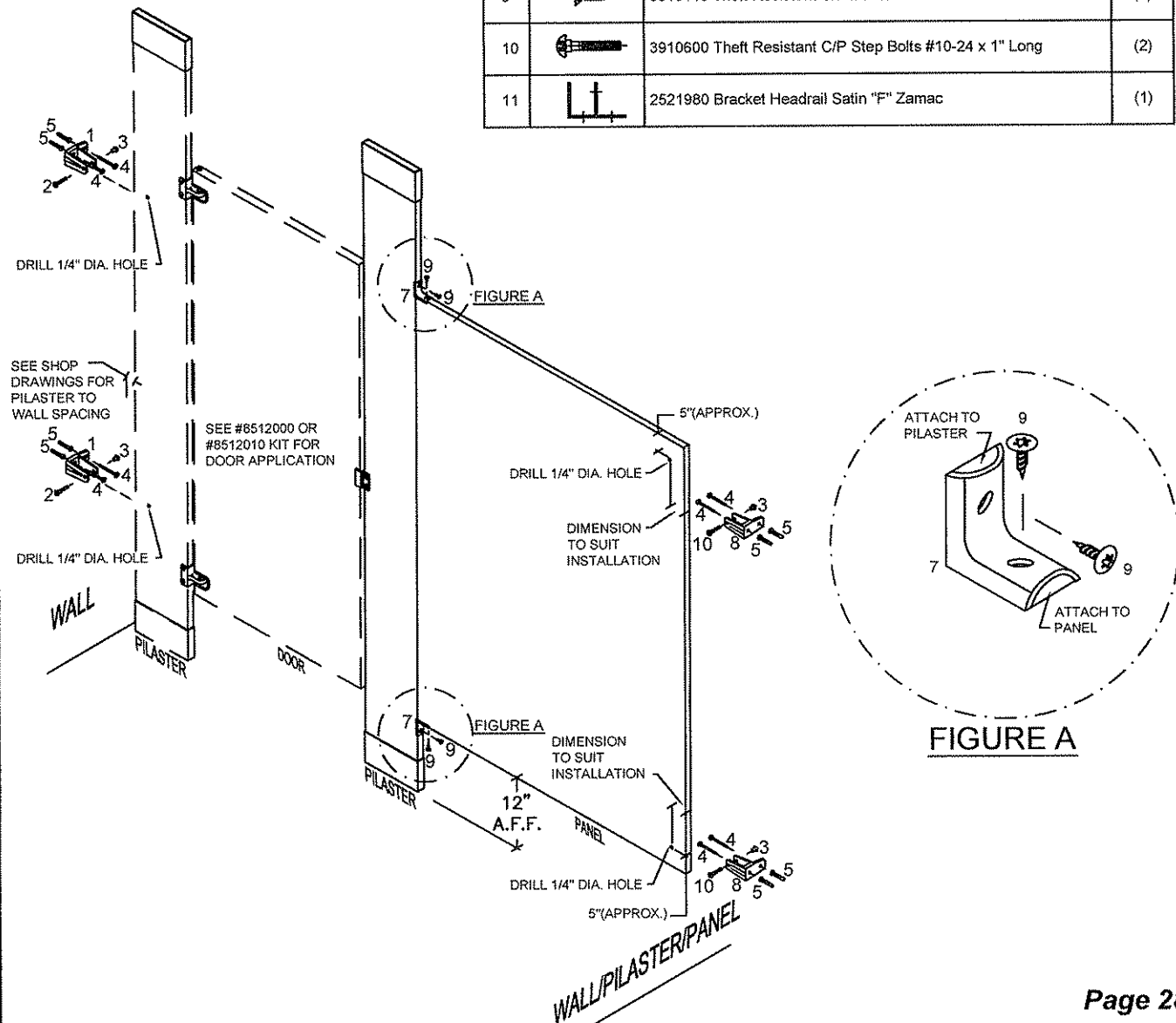

**FLOOR AND CEILING ANCHORED
 PILASTER/PANEL ALCOVE
 ASSEMBLY
 PLASTIC LAMINATE**

Replace #8517310 with #8517320 for two ear bracket kit.

Alcove Hardware Kit (P/N 8517310) Includes: CHROME PLATED ZAMAC		
PART ID.	DESCRIPTION	QTY
1	 2511840 1 1/4" One Ear Wall Bracket	(2)
2	 3910700 Theft Resistant C/P Step Bolts #10 -24 x 1 1/4" Long	(2)
3	 3910690 Theft Resistant C/P Barrel Nut	(4)
4	 3910450 Theft Resistant C/P #14 x 2 1/2" S.M.S	(10)
5	 3080000 Plastic Shields	(10)
6	 3914120 Theft Resistant C/P #14 x 5/8" S.M.S (Balance For Fastening Pilaster /Panel)	(14)
7	 2511950 Alcove Clip	(2)
8	 2511760 1" One Ear Wall Bracket	(2)
9	 3910110 Theft Resistant C/P #10 x 1" S.M.S	(4)
10	 3910600 Theft Resistant C/P Step Bolts #10-24 x 1" Long	(2)
11	 2521980 Bracket Headrail Satin "F" Zamac	(1)



**FLOOR AND CEILING ANCHORED
PILASTER/PANEL/PILASTER INLINE
ASSEMBLY
PLASTIC LAMINATE**

Alcove Hardware Kit (P/N 8517030) Includes: CHROME PLATED ZAMAC			
PART ID.		DESCRIPTION	QTY
1		2518340 Alcove Clips	(12)
2		3910600 Theft Resistant C/P Step Bolts #10-24 x 1" Long	(12)
3		3910690 Theft Resistant C/P Barrel Nut	(12)
4		3914120 Theft Resistant C/P #14 x 5/8" S.M.S	(12)

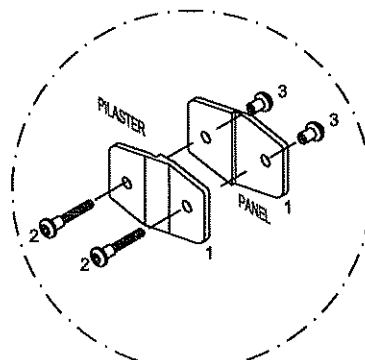
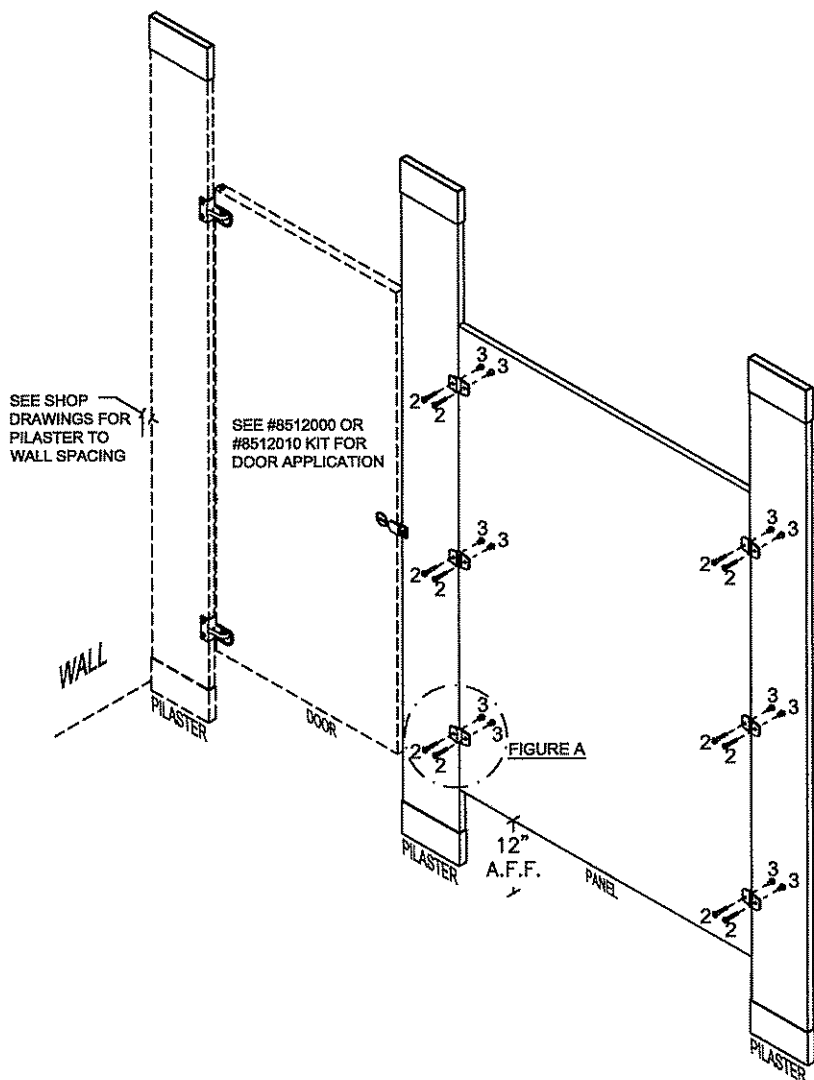
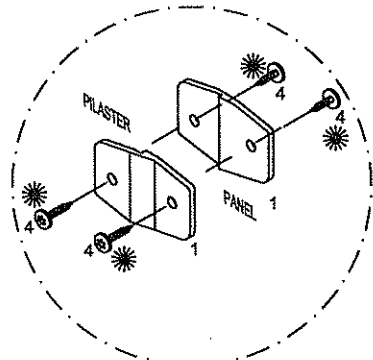









FIGURE A
RECOMMENDED



OPTIONAL

* Two #3914120 Theft resistant C/P #14 X 5/8" May be Used (But Not Recommended) To Fasten brackets To Panel. Offset brackets for screw clearance.





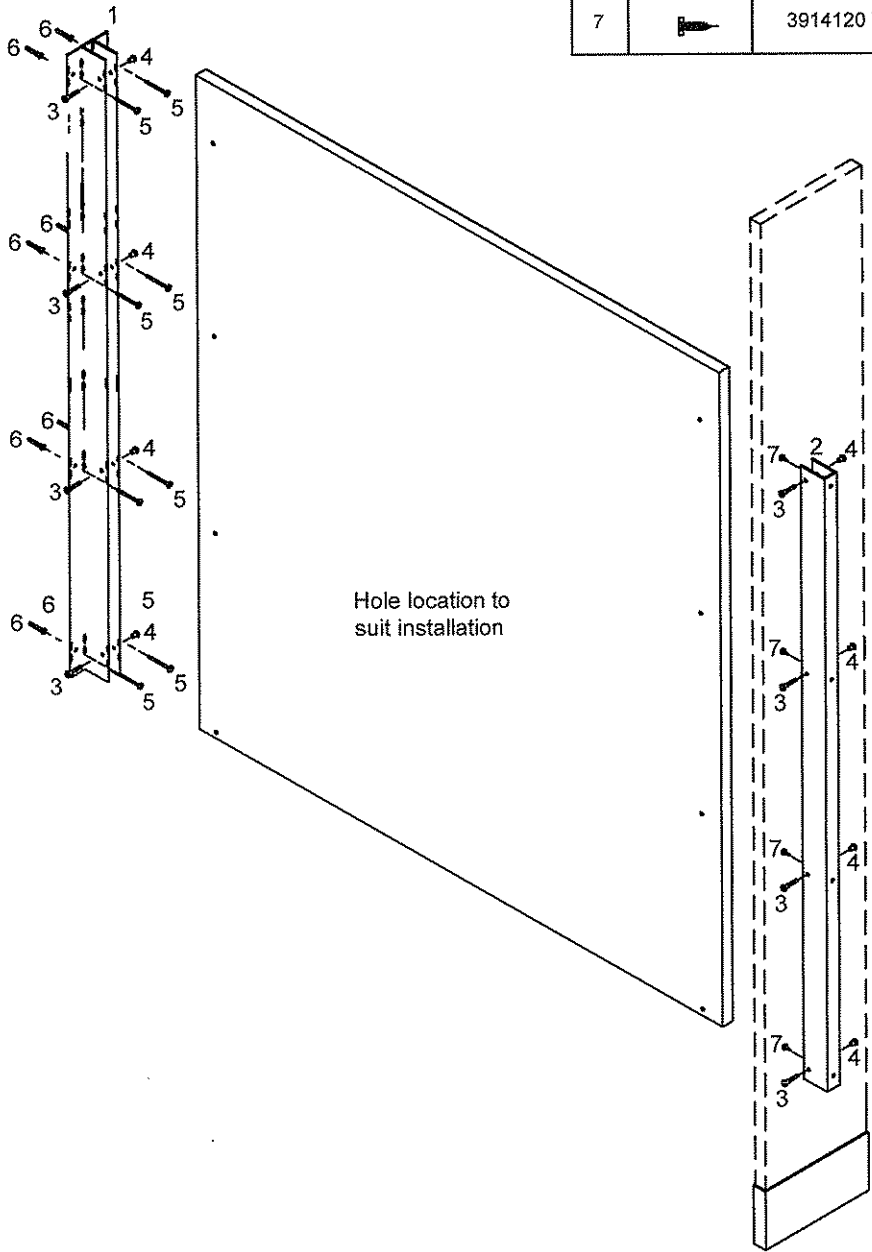

**FLOOR ANCHORED/OVERHEAD BRACED
PANEL TO PILASTER/WALL
TWO EAR ASSEMBLY
PLASTIC LAMINATE**

Panel Hardware Kit (P/N 8446020) Includes: ALUMINUM FULL HEIGHT		
PART ID.	DESCRIPTION	QTY
1	 5442750 Two Ear Bracket	(1)
2	 5449540 "U" Bracket	(1)
3	 3910600 Theft Resistant C/P Step Bolts 1" Long	(12)
4	 3910690 Theft Resistant C/P Barrel Nut	(12)
5	 3910450 Theft Resistant C/P #14 x 2 1/2" S.M.S	(12)
6	 3080000 Plastic Shields	(12)
7	 3914120 Theft Resistant C/P #14 x 5/8" S.M.S	(12)



**FLOOR ANCHORED/OVERHEAD BRACED
PANEL TO PILASTER/WALL
TWO EAR ASSEMBLY
PLASTIC LAMINATE**

Panel Hardware Kit (P/N 8446010) Includes:
ALUMINUM FULL HEIGHT

PART ID.	DESCRIPTION	QTY
1	 5442760 One Ear Bracket	(1)
2	 5449540 "U" Bracket	(1)
3	 3910600 Theft Resistant C/P Step Bolts 1" Long	(12)
4	 3910690 Theft Resistant C/P Barrel Nut	(12)
5	 3910450 Theft Resistant C/P #14 x 2 1/2" S.M.S	(12)
6	 3080000 Plastic Shields	(12)
7	 3914120 Theft Resistant C/P #14 x 5/8" S.M.S	(12)

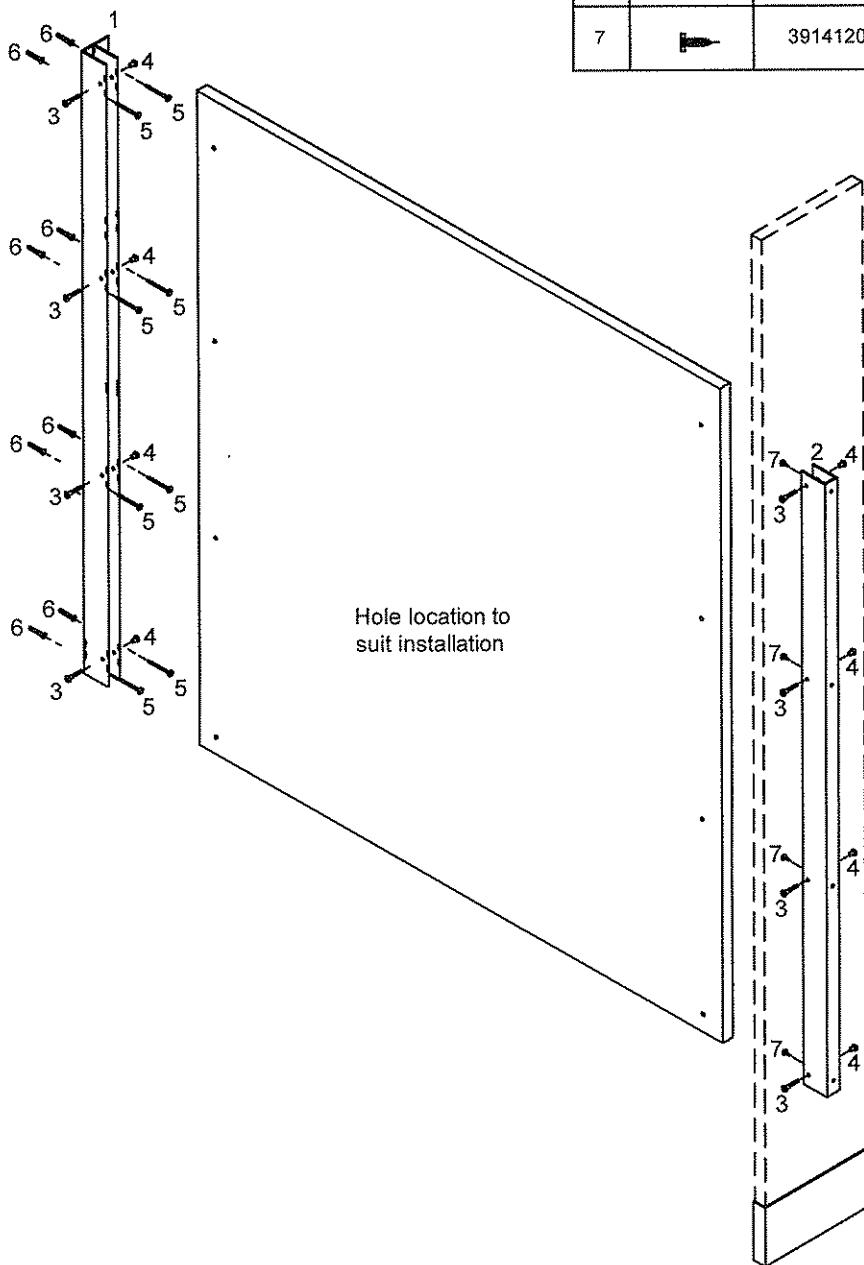









MANNING MATERIALS INC

FLOOR ANCHORED/OVERHEAD BRACED PILASTER/WALL ASSEMBLY PLASTIC LAMINATE



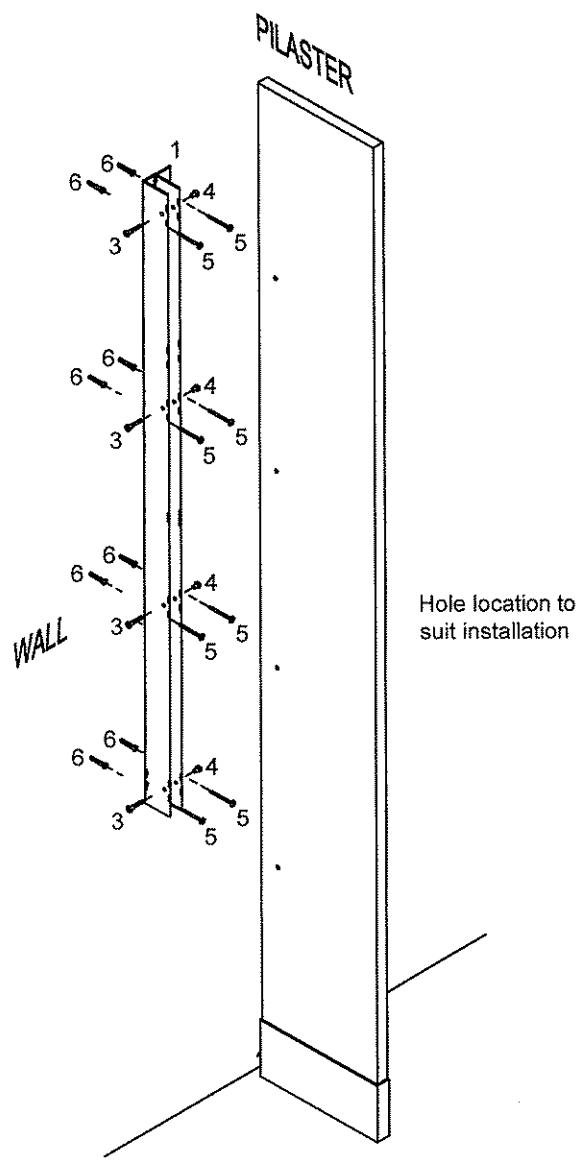

Pilaster/Wall Hardware Kit (P/N 8446210) Includes:
ALUMINUM FULL HEIGHT

PART ID.	DESCRIPTION	QTY
1	 5441840 One Ear Wall Bracket	(2)
2	 3910700 Theft Resistant C/P Step Bolts 1 1/4" Long	(6)
3	 3910690 Theft Resistant C/P Barrel Nut	(6)
4	 3910450 Theft Resistant C/P #14 x 2 1/2" S.M.S	(12)
5	 3080000 Plastic Shields	(12)
6	 3914120 Theft Resistant C/P #14 x 5/8" S.M.S	(8)



**URINAL SCREEN FULL HEIGHT
ASSEMBLY
PLASTIC LAMINATE**

- A. Before proceeding, confirm that backing of wall is adequate to support and secure mounting of urinal screens.
- B. Insert anchoring devices in walls and secure wall brackets.
- C. Place urinal screen on a support, 12" above the floor.
- D. Set it into wall bracket and fasten urinal screen at this time.

Urinal Screen Hardware Kit (P/N 8449000) Includes: ALUMINUM FULL HEIGHT			
PART ID.		DESCRIPTION	QTY
1		5449000 38" Long Two Ear Wall U/S Bracket	(1)
2		3910450 Theft Resistant C/P #14 x 2 1/2" S.M.S	(8)
3		3080000 Plastic Shields	(8)
4		3910600 Theft Resistant C/P Step Bolts 1" Long	(4)
5		3910690 Theft Resistant C/P Barrel Nut	(4)

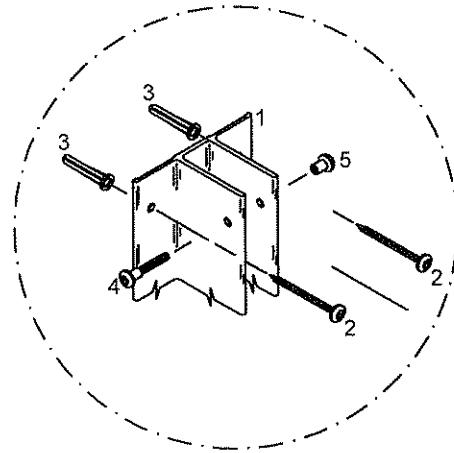
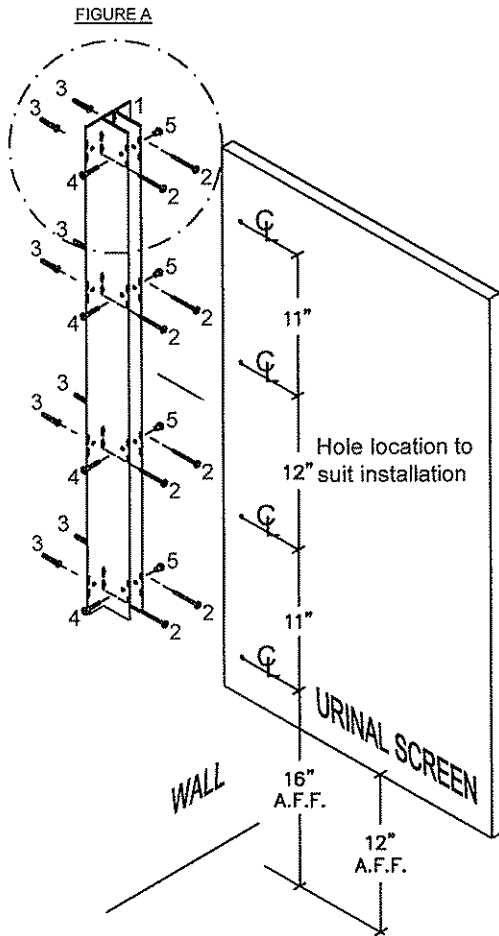

FIGURE A

CARE AND MAINTENANCE OF TOILET PARTITIONS

In order to provide toilet partitions with the care and maintenance, the following instructions must be followed.

- A. All surfaces must be kept clean with water and a mild soap solution only.
- B. In high humidity areas, the rooms must be properly ventilated.
- C. "Hosing down" or wet washing of these units may cause water damage.
- D. For maximum protection, periodic application of any standard furniture wax will be beneficial.
- E. In order to provide toilet partitions with the proper care and maintenance, the above instructions must be followed.

WARNING

Under no circumstances should these components be subjected to:

- *Abrasive powders or pads
- *Water closet cleaners
- *Ceramic tile cleaners
- *Solutions containing more than 1 % by volume of ammonia
- *Solutions containing acids or lye
- *Solutions containing enzymes

Attention to work progress during new construction or renovation is important.

Other trades and cleaning services may use agents for ceramics and tiles that will damage these components